

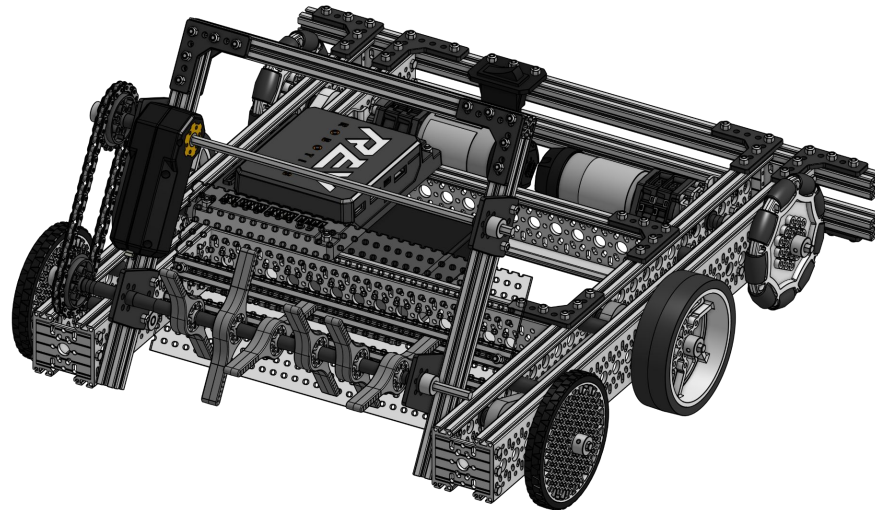

2026-27 REV DUO FTC Starter Bot Base Build Guide



Bill of Materials

PART NUMBER	DESCRIPTION	QTY	PART NUMBER	DESCRIPTION	QTY
REV-31-1387	Switch Cable and Bracket	1	REV-41-1324	3mm Spacer	21
REV-31-1595	Control Hub	1	REV-41-1702	Tensioning Bushing - 39mm	8
REV-31-1302	12V Slim Battery	1	REV-41-1338	10 Tooth #25 Sprocket	8
REV-41-1166	Battery Holder Plate	1	REV-41-1327	Shaft Collars	16
REV-41-1305	15mm Plastic 90 Degree Bracket	18	REV-41-1190	90mm Omni Wheel	2
REV-41-1767	45mm x 15mm C Channel - 248mm	2	REV-41-1329	Through Bore Bearing - Long	7
REV-41-1365	#25 Roller Chain - 10 ft	1	REV-41-1687	U Channel Endcap	4
REV-41-1267	90mm Grip Wheel	2	REV-41-1323	15mm Spacer	11
REV-41-1354	90mm Traction Wheel	2	REV-41-1621	UltraPlanetary Outside Mounting Bracket	2
REV-41-1615	UltraPlanetary Female 5mm Hex Output V2	2	REV-41-1432	15mm Extrusion - 420mm - 90° Ends	5
REV-41-1607	UltraPlanetary 550 Motor Plate	2	REV-41-1359	M3 x 8mm Hex Cap Screw	180
REV-41-1291	HD Hex Motor No Gearbox	2	REV-41-1361	M3 Nyloc Nut	135
REV-41-1608	UltraPlanetary 550 Motor Pinion Gear - 13 Tooth	2	REV-41-1360	M3 x 16mm Hex Cap Screw	8
REV-41-1603	UltraPlanetary Cartridge - 5:1	2	REV-41-1321	15mm Plastic Lap Corner Bracket	4
REV-41-1602	UltraPlanetary Cartridge - 4:1	2	REV-41-2702	Flap Wheel - 5mm Hex Bore - Medium	6
REV-41-1609	UltraPlanetary Hardware Pack	2	REV-41-1300	Core Hex Motor	1
REV-41-1348	5mm x 90mm Hex Shaft	6	REV-41-1303	15mm Plastic Motion Bracket	4
REV-41-1326	Through Bore Bearing - Short	14	REV-41-1340	20 Tooth #25 Sprocket	2
REV-41-1492	M3 Standoff - 40mm	8	REV-41-1431	15mm Extrusion - 225mm - 90° Ends	2
REV-41-1762	45mm x 15mm C Channel - 408mm	4	REV-41-1362	5mm x 400mm Hex Shaft	2

Cut List

Extrusion can be cut with either a hand-held hacksaw or with a band saw. Be sure that the pieces are properly secured, ideally with clamps, before cutting. Using a circular or chop saw is NOT recommended.

Cut from 15mm Extrusion - 420mm - 90° Ends

Length	QTY	Assembly
248 mm	3	Intake

Cut from 5mm x 400mm Hex Shaft

Length	QTY	Assembly
308 mm	2	Intake

Cut from Polycarbonate Sheet - 2mm - 8mm Grid Pattern

Length	QTY	Assembly
248mm x 112mm	1	Intake

Create from #25 Roller Chain - 10 ft

Length	QTY	Assembly
54 Links	1	Intake

Related Guides

Chain Tool instructions



<https://docs.revrobotics.com/how-to-chain>

Ultra Planetary Assembly Instructions

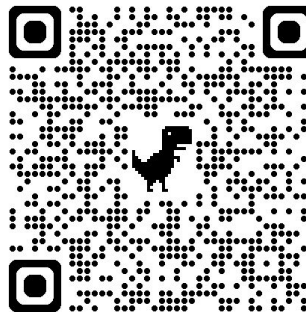

<http://docs.revrobotics.com/build-up-gearbox>

Channel Drivetrain

Before beginning this Build Guide, you will need to assemble a Channel Drivetrain. Follow these instructions to build one.

Note: Both the Channel Drivetrain and the 2026-27 REV DUO FTC Starter Bot Base can be constructed from a FTC Starter Kit V3.1.

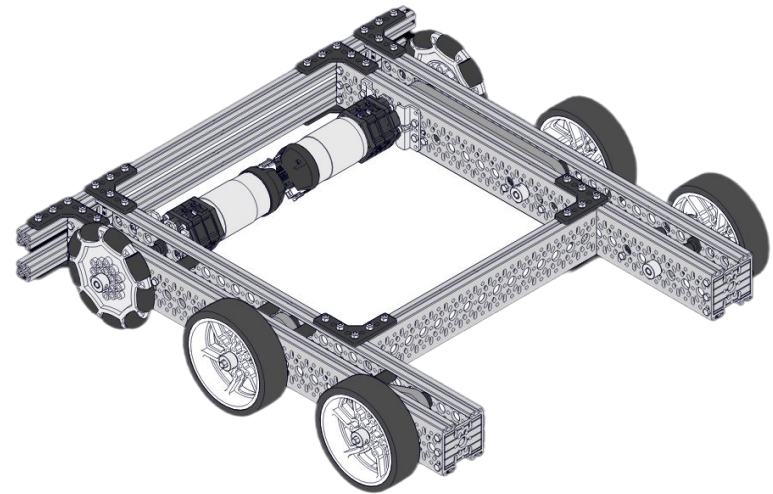
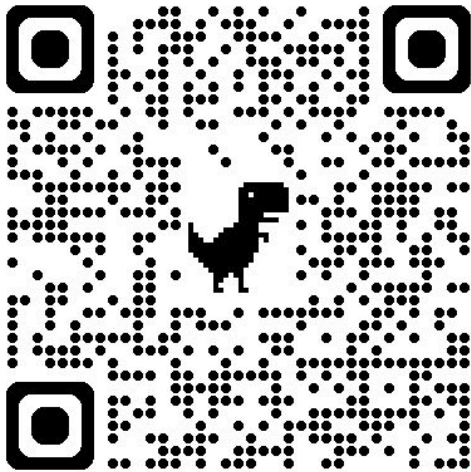

<http://docs.revrobotics.com/build-channel-drivetrain>

1

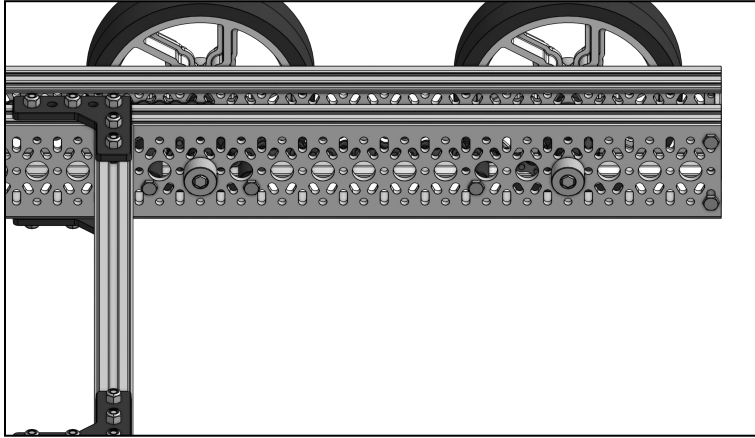

Get:

- 1 - Channel Drivetrain

locate which side has the chain tensioners on either side of your Channel Drivetrain are installed on the low side

Please Note: You may find that neither side of the Channel Drivetrain has low side or that both are already on the upper side. This is fine, you just need to turn your drivetrain over and make sure that both sides have the chain tensioners on the upper holes as shown in the next image.

2

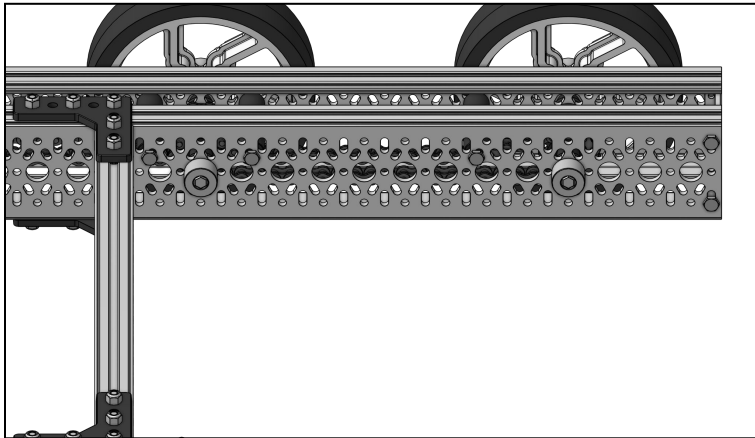

Using the Channel Drivetrain Buide Guide linked at the beginning of this guide, move the chain tensioners to the upper the holes as shown so that the chanin runs under the chain tensioners.

3

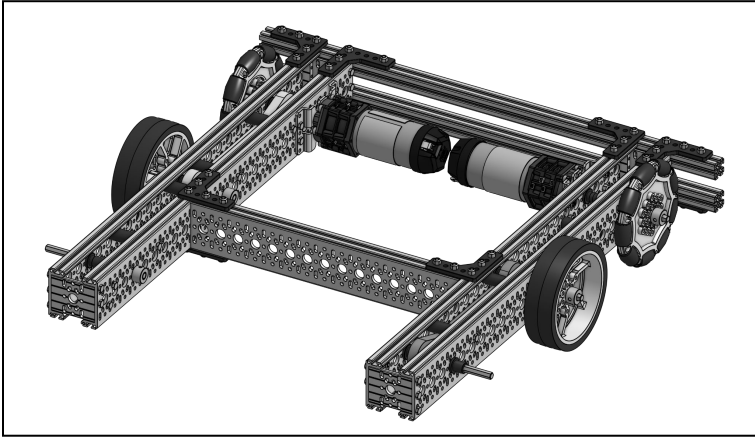

Remove the front Grip Wheels from the Channel Drivetrain.

4

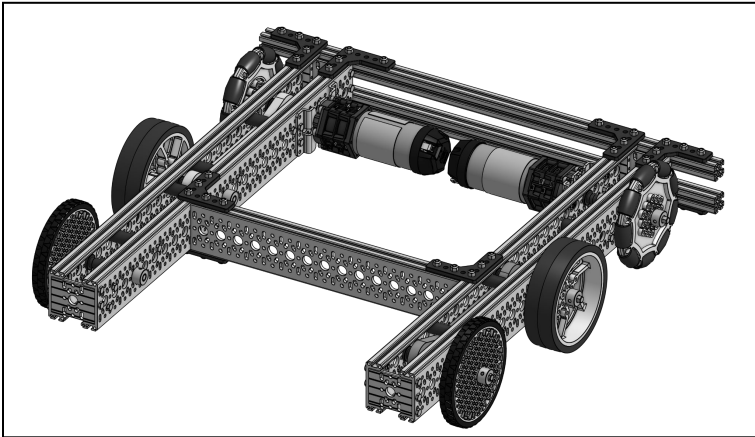

Get:

- 2 - 90mm Traction Wheel
- 2 - Shaft Collars

Install two Traction Wheels onto the front of your Channel Drivetrain. Secure the wheels with shaft collars.

5

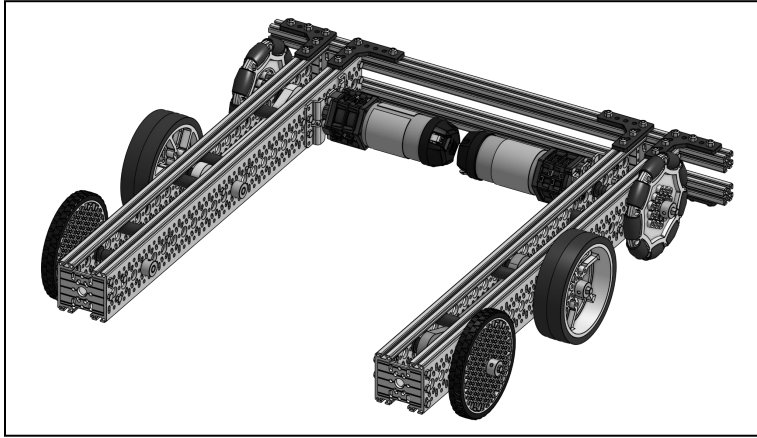

Remove the center C Channel and four 90 Deg brackets from the Channel Drivetrain.

6

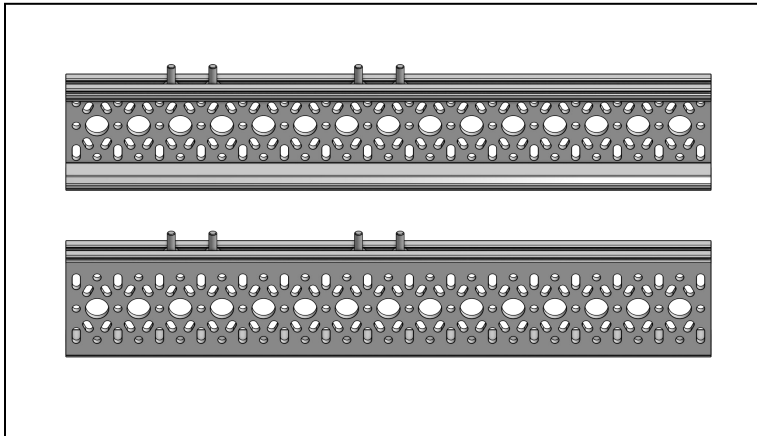

Get:

- 2 - 248mm C Channel
- 8 - M3 x 8mm Hex Cap Screws

Slide four Hex Cap screws into the C Channel. Do this twice.

7

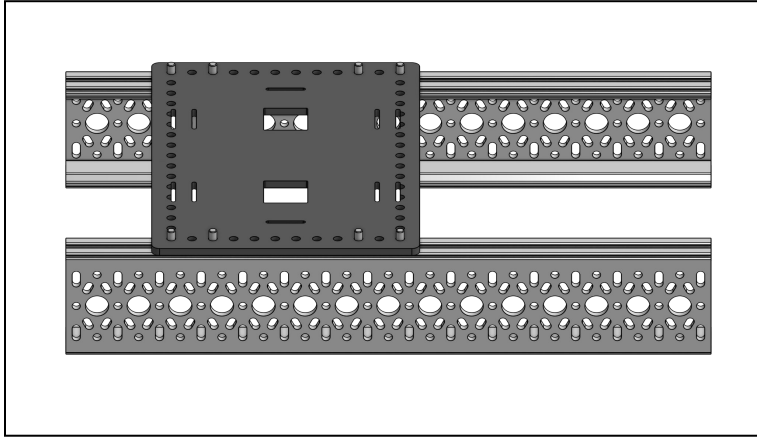

Get:

- 1 - Battery Holder Plate

Slide the Battery Holder Plate onto the eight Hex Cap screws.

8

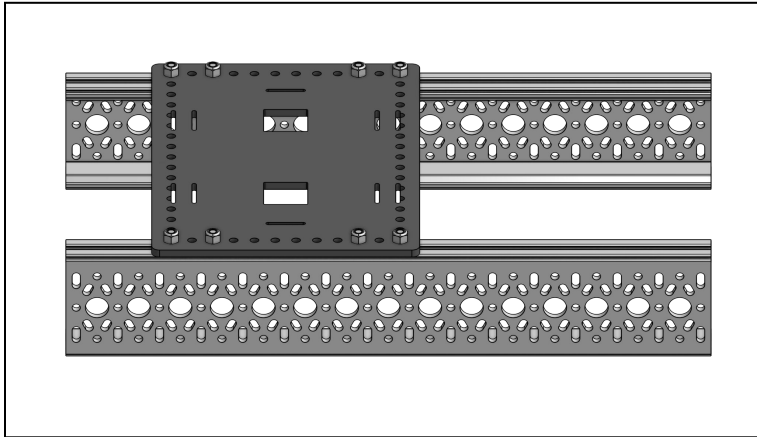

Get:

- 8 - Nyloc Nuts

Secure the Battery Plate with eight Nyloc Nuts.

9

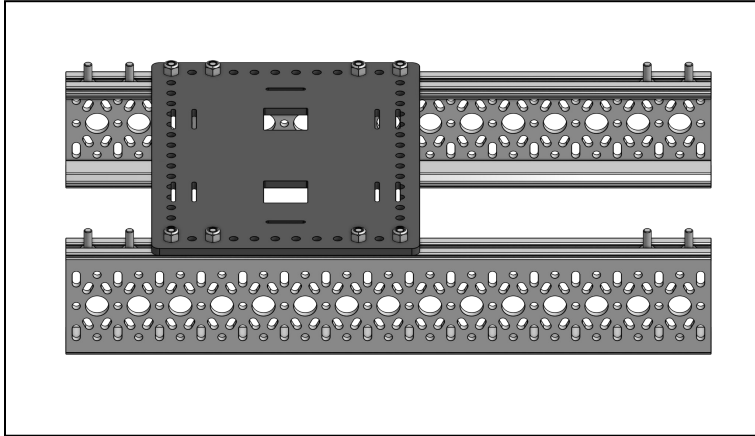

Get:

- 8 - M3 x 8mm Hex Cap Screws

Slide four Hex Cap screws into the C Channel as shown. Do this on both C Channel.

10

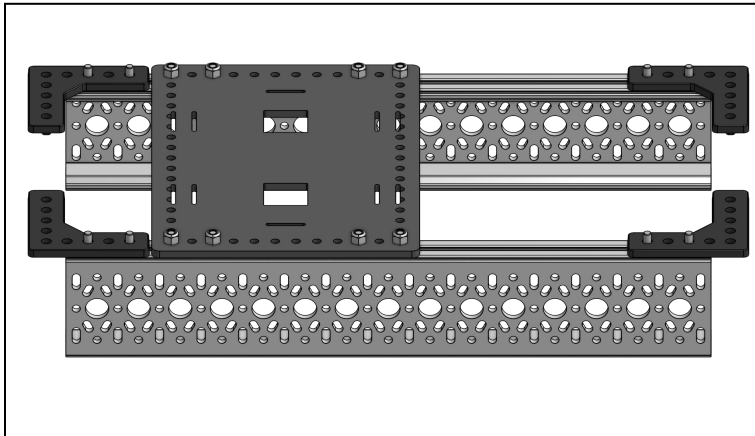

Get:

- 4 - 15mm Plastic 90 Degree Brackets

Slide four 90 Degree Brackets onto the Hex Cap screws as shown.

11

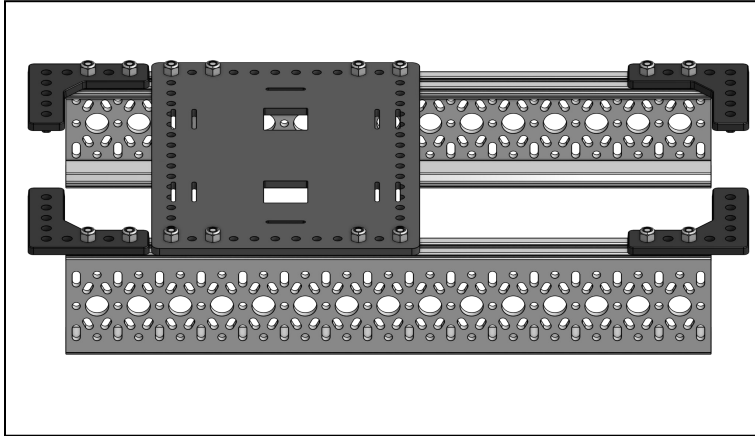

Get:

- 8 - Nyloc Nuts

Secure the 90 Degree Brackets with Nyloc Nuts.

12

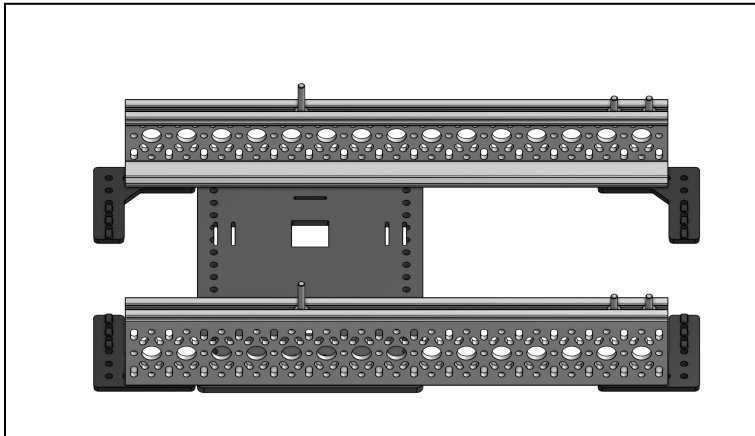

Get:

- 4 - M3 x 8mm Hex Cap Screws
- 2 - M3 x 16mm Hex Cap Screws

Slide two 8mm Hex Cap screws and one 16mm Hex cap screw into the C Channel as shown. Do this on both C Channel.

Please Note: It is recommend to use some tape to keep these screws from sliding out during the next few steps but it is not required.

13

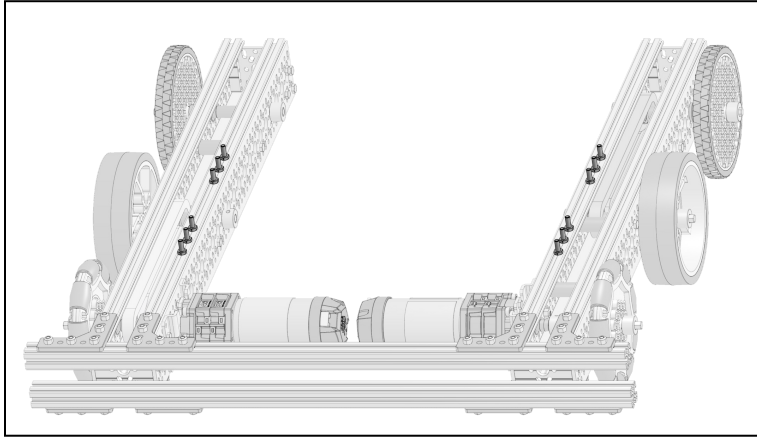

Get:

- 12 - M3 x 8mm Hex Cap Screws

Slide 12 Hex Cap screws into the Channel Drivetrain as shown.

14

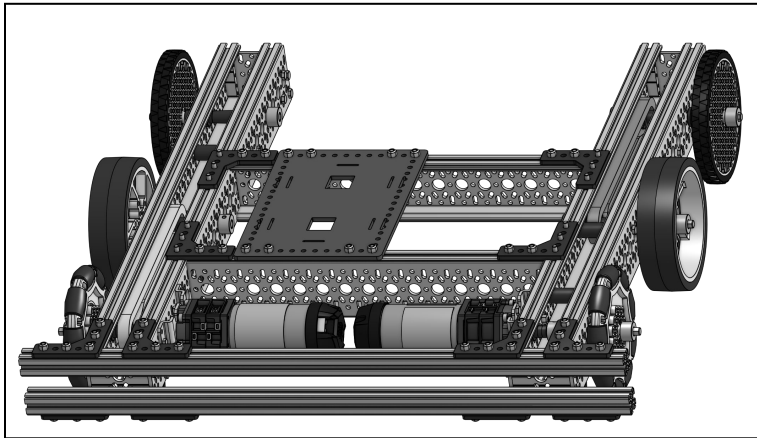

Slide the Battery Plate Holder assembly onto the Hex Cap screws as shown.

15

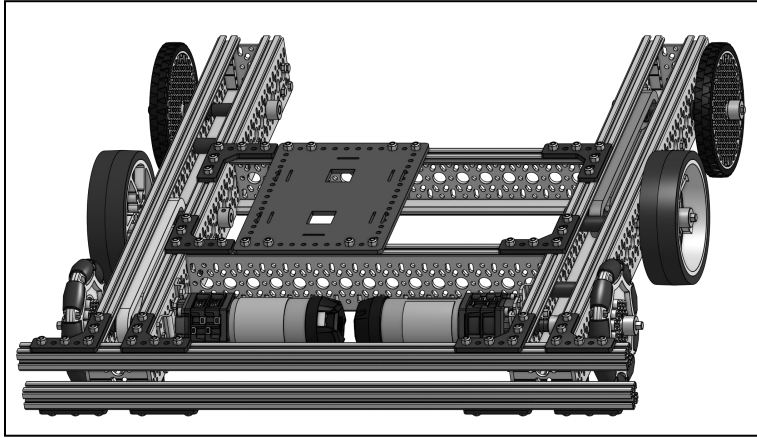

Get:

- 12 - Nyloc Nuts

Secure the 90 Degree Brackets with Nyloc Nuts.

16

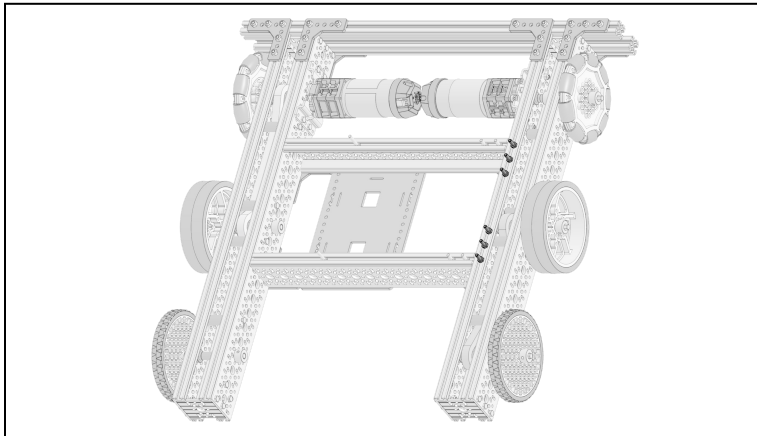

Get:

- 6 - M3 x 8mm Hex Cap Screws

Flip the Channel Drivetrain over from the previous step.

Slide 6 Hex Cap screws into the Channel Drivetrain as shown.

17

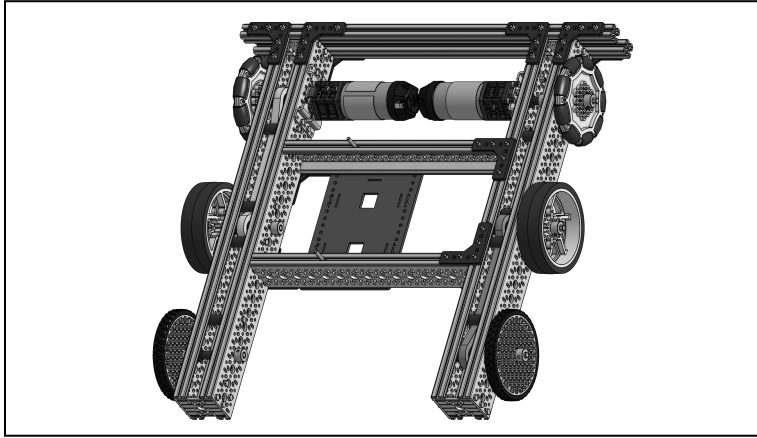

Get:

- 2 - 15mm Plastic 90 Degree Brackets

Slide two 90 Degree Brackets onto the 8mm Hex Cap screws from steps 12 and 16 as shown.

18

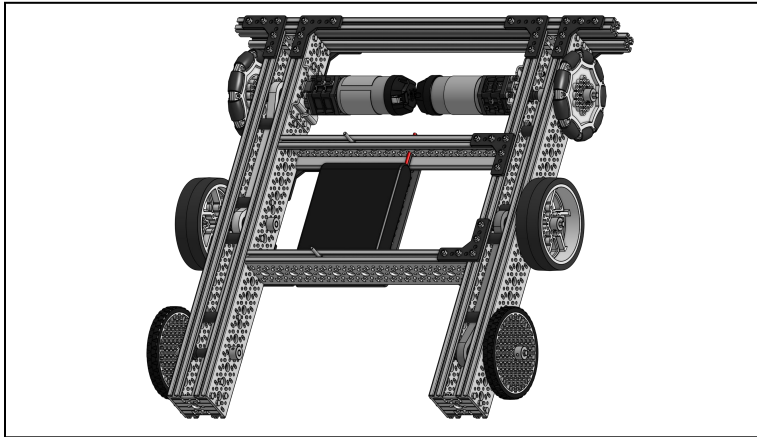

Get:

- 10 - Nyloc Nuts
- 1 - Roll of Hook and Loop Fastener
- 1 - 12V Slim Battery

Secure the 90 Degree Brackets with Nyloc Nuts.

Cut strips of the Hook and Loop Fastener to create a secure harness for the 12V Slim Battery. Once this is done remove the battery for safety purposes until you have completed this guide.

Please Note: This guide will show images of the battery in future images, this is for your reference and orientation.

19

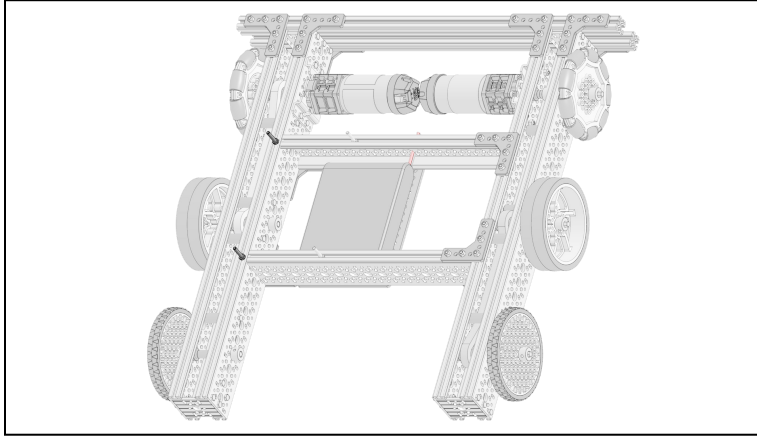

Get:

- 2 - M3 x 16mm Hex Cap Screws

Slide two 16mm Hex cap screws into the C Channel as shown.

20

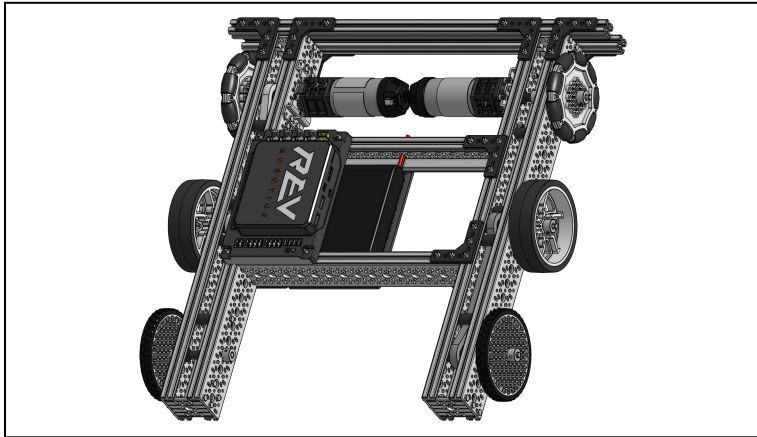

Get:

- 1 - Control Hub

Slide the Control Hub onto the 16mm Hex Cap screws from steps 12 and 19 as shown.

21

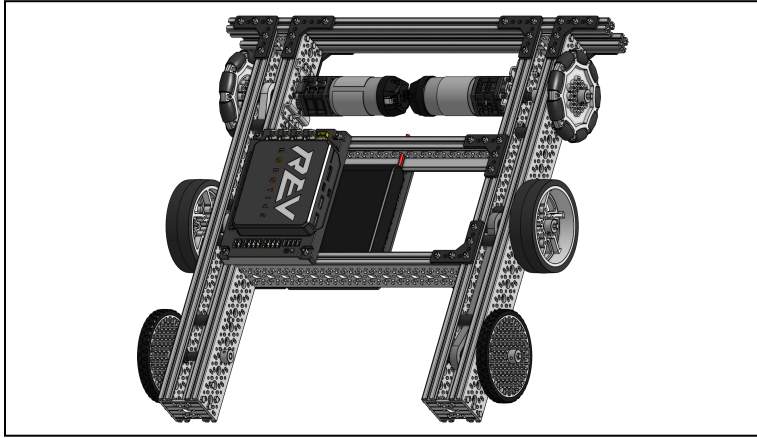

Get:

- 4 - Nyloc Nuts

Secure the Control Hub with Nyloc Nuts.

22

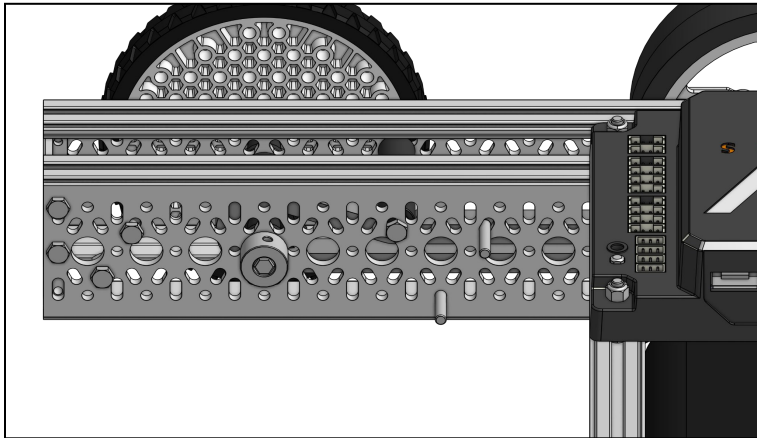

Get:

- 2 - M3 x 16mm Hex Cap Screws

Insert 2 Hex Cap screws into the locations shown.

Please Note: You may find it helpful to have the Channel Drivetrain on it's side for this step.

23

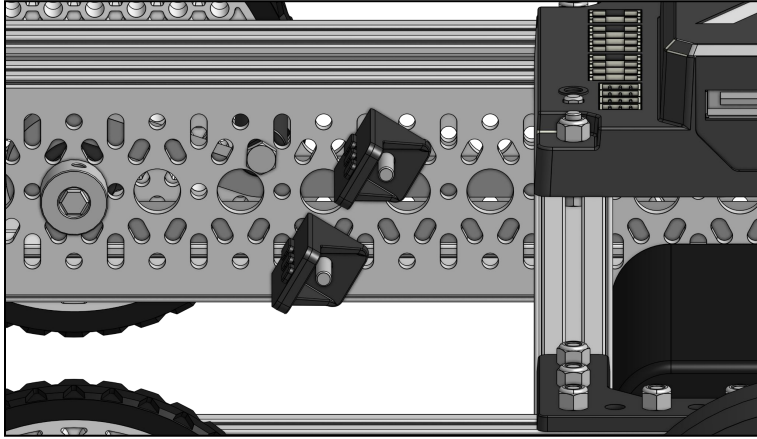

Get:

- 2 - 15mm Plastic Lap Corner Brackets

Slide Lap Corner Brackets onto the Hex Cap screws as shown.

24

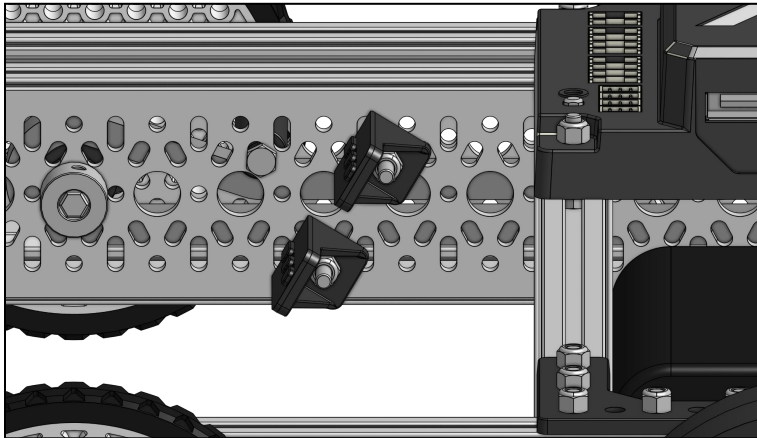

Get:

- 2 - Nyloc Nuts

Secure the Lap Corner Brackets with Nyloc Nuts.

25

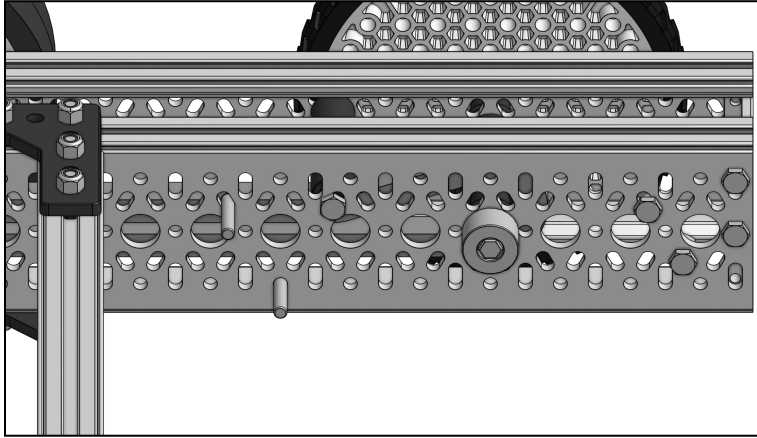

Get:

- 2 - M3 x 16mm Hex Cap Screws

Insert 2 Hex Cap screws into the locations shown.

Please Note: You may find it helpful to have the Channel Drivetrain on it's side for this step.

26

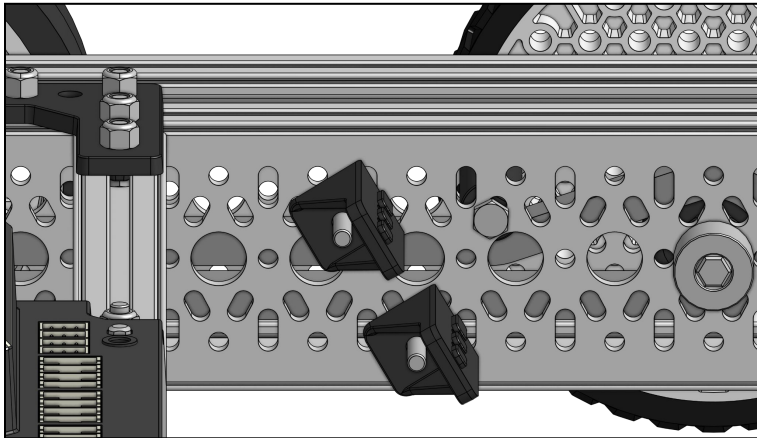

Get:

- 2 - 15mm Plastic Lap Corner Brackets

Slide Lap Corner Brackets onto the Hex Cap screws as shown.

27

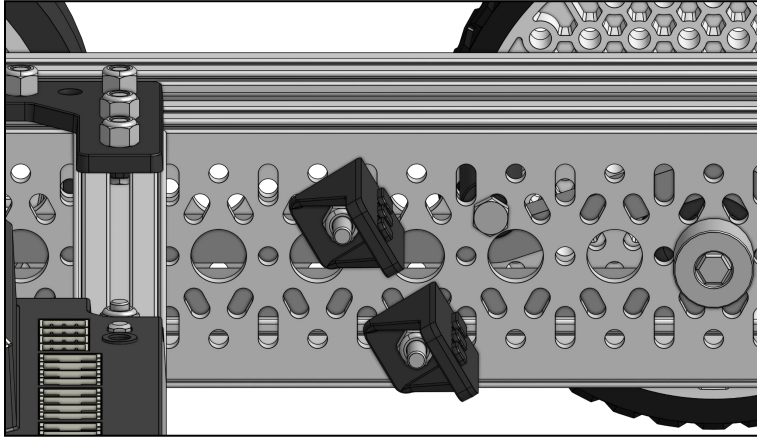

Get:

- 2 - Nyloc Nuts

Secure the Lap Corner Brackets with Nyloc Nuts.

28

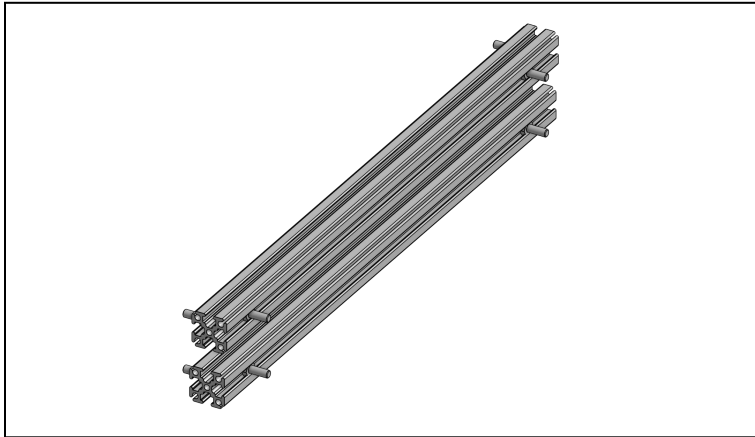

Get:

- 2 - 15mm Extrusion - Cut to 248mm
- 8 - M3 x 8mm Hex Cap Screws

Slide two 8mm Hex cap screws into each side of a 248mm Extrusion. Do this twice.

29

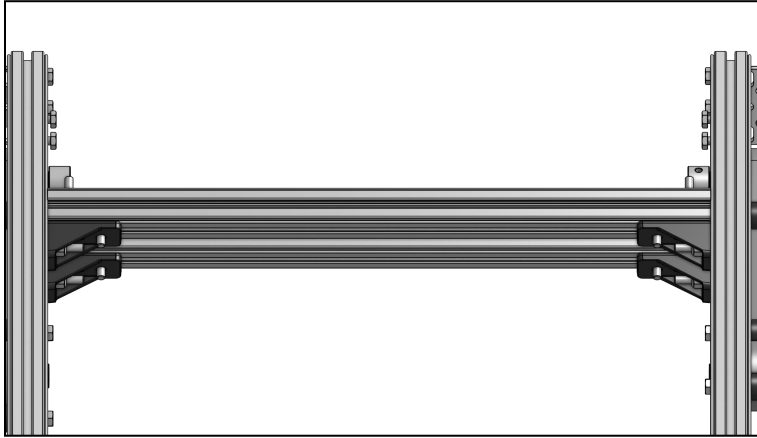

Get:

- 2 - 15mm Extrusion - Cut to 248mm
- 8 - M3 x 8mm Hex Cap Screws

Slide the Extrusion so that the Hex Cap Screws inster into the Lap Corner Brackets as shown. Do this twice

Please Note: Some componets of the Channel Drivetrain are hidden in this image for visibility.

30

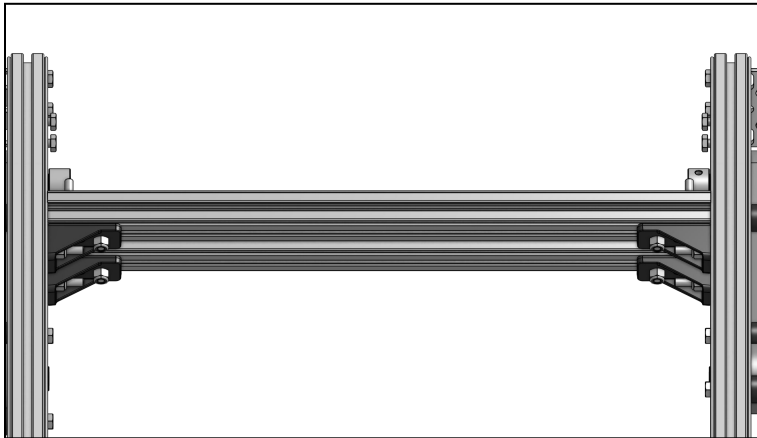

Get:

- 4 - Nyloc Nuts

Secure the Extrusion to the Lap Corner Brackets with Nyloc Nuts shown.

Please Note: Some componets of the Channel Drivetrain are hidden in this image for visibility.

31

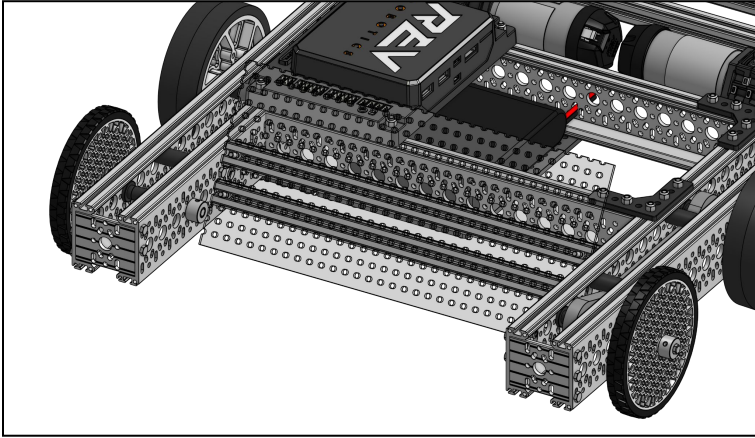

Get:

- 1 - Polycarbonate Sheet - 2mm - 8mm Grid Pattern cut to 248mm x 112mm

Slide the Polycarbonate Sheet onto the Hex Cap screws so that the screws are through the 4th and 7th holes from the bottom.

32

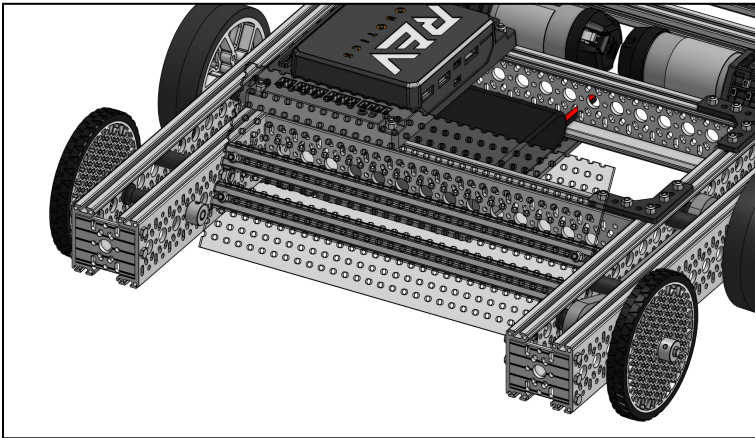

Get:

- 4 - Nyloc Nuts

Secure the Polycarbonate Sheet to the Extrusion with Nyloc Nuts shown.

33

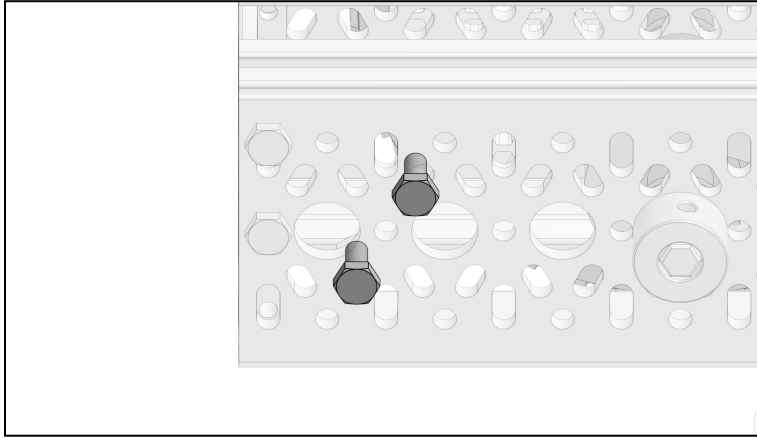

Get:

- 2 - M3 x 8mm Hex Cap Screws
- 2 - Nyloc Nuts

Insert two Hex Cap screws into the locations shown. start two Nyloc nuts onto the Hex Cap screws but keep these loose for later steps.

34

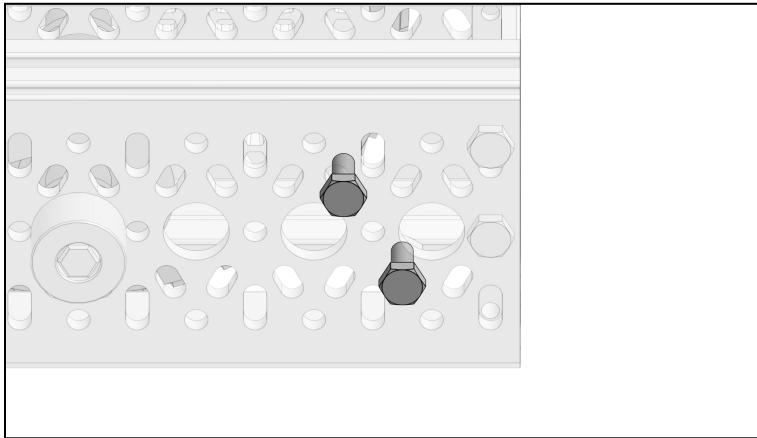

Get:

- 2 - M3 x 8mm Hex Cap Screws
- 2 - Nyloc Nuts

Insert two Hex Cap screws into the locations shown. start two Nyloc nuts onto the Hex Cap screws but keep these loose for later steps.

35

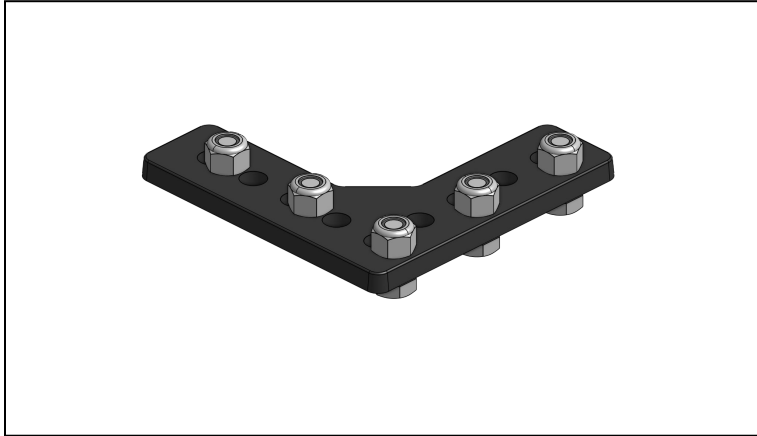

Get:

- 4 - 15mm Plastic 90 Degree Brackets
- 20 - M3 x 8mm Hex Cap Screws
- 20 - Nyloc Nuts

Pre-Load four 90 Degree Brackets with five Hex Cap screws and five Nuloc Nuts. Do not tighten these nuts, keep these loose for later steps.

36

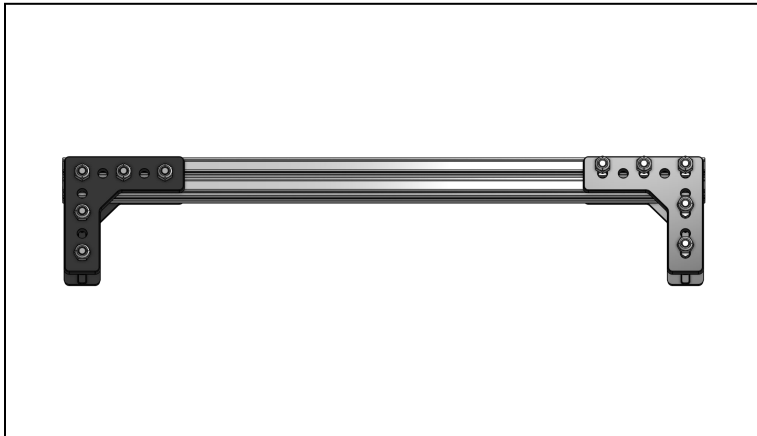

Get:

- 1 - 15mm Extrusion - Cut to 248mm

Slide the four Pre-Loaded Brackets onto the 248mm Extrusion. Tighten the twelve Nyloc Nuts to secure the Brackets to the Extrusion.

37

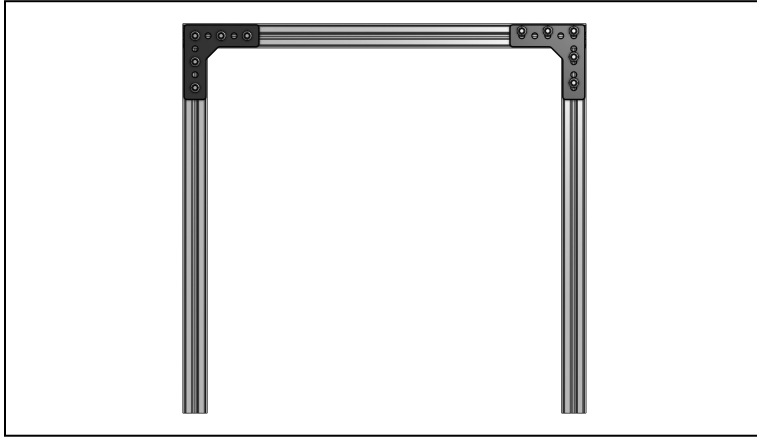

Get:

- 2 - 15mm Extrusion - 225mm - 90° Ends

Slide 2 225mm Extrusion into the four Pre-Loaded Brackets. Tighten the eight Nyloc Nuts to secure the Extrusion to the Brackets.

38



Get:

- 4 - 15mm Plastic Motion Bracket
- 8 - M3 x 8mm Hex Cap Screws
- 8 - Nyloc Nuts

Pre-Load four Motion Brackets with two Hex Cap screws and two Nuloc Nuts. Do not tighten these nuts, keep these loose for later steps.

Get:

- 1 - 5mm Hex Shaft cut to 308mm
- 2 - Pre-Loaded Motion Brackets
- 1 - Core Hex Motor
- 2 - Shaft Collars
- 1 - 20 Tooth #25 Sprocket
- 1 - 15mm Spacer
- 1 - Through Bore Bearing - Long

Slide the following on to the Hex Shaft from left to right:

- 1 - Shaft Collar, 1 - 20 Tooth #25 Sprocket, 1 - 15mm Spacer, 1 - Pre-Loaded Motion Bracket with the Hex Cap facing inwards, 1 - Core Hex Motor, 1 - Pre-Loaded Motion Bracket with the Hex Cap facing inwards, 1 - Through Bore Bearing, 1 - Shaft Collar.



Get:

- 1 - 5mm Hex Shaft cut to 308mm
- 2 - Pre-Loaded Motion Brackets
- 5 - 3mm Spacer
- 2 - Shaft Collars
- 1 - 20 Tooth #25 Sprocket
- 8 - 15mm Spacer
- 2 - Through Bore Bearing - Long
- 6 - Flap Wheel - 5mm Hex Bore - Medium

Slide the following on to the Hex Shaft from left to right:

- 1 - Shaft Collar, 1 - 20 Tooth #25 Sprocket, 3 - 3mm Spacer, 1 - 15mm Spacer, 1 - 3mm Spacer, Through Bore Bearing - Long, 1 - Pre-Loaded Motion Bracket with the Hex Cap facing outwards, 2 - 15mm Spacer, 1 - Flap Wheel, 1 - 15mm Spacer, 1 - Flap Wheel, 1 - 15mm Spacer, 1 - Flap Wheel, 1 - 15mm Spacer, 1 - Flap Wheel, 1 - 15mm Spacer, 1 - Flap Wheel, 1 - 15mm Spacer, 1 - Pre-Loaded Motion Bracket with the Hex Cap facing outwards, 1 - Through Bore Bearing, 1 - Shaft Collar.

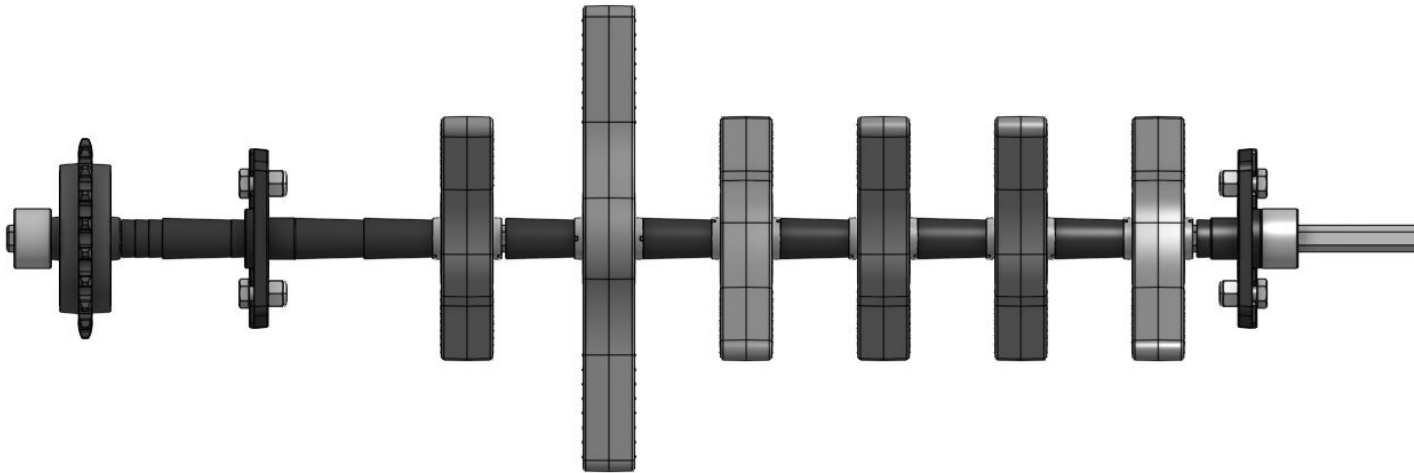

41

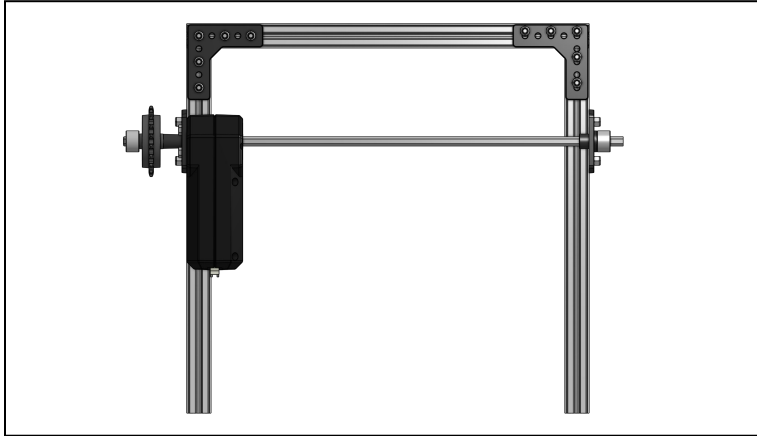

Slide the powered shaft onto the outside of the Extrusion as shown. Tighten the Nyloc Nuts enough to keep it from sliding but you will need to adjust this later.

42

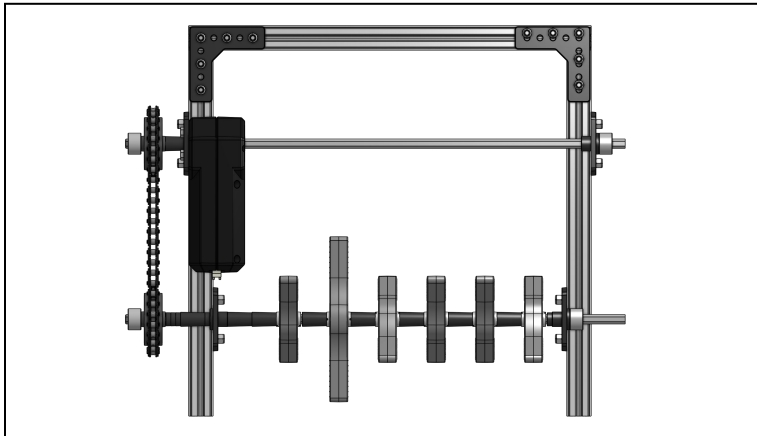

Get:

- 1 - 54 Link Chain

Slide the Flap Wheel shaft onto the inside of the Extrusion as shown. Loop the Chain around the two Sprockets and slide them apart until it's tighten. Tighten the Nyloc Nuts enough to keep it from sliding but you will need to adjust this later.

Slide the intake assembly onto the Hex Caps from steps 33 and 34 as shown. Using the 5.5mm Combination Wrench tighten the Nyloc nuts to secure the Intake to the Channel Drivetrain.

Adjust the shafts so that the bottom of the Flap Wheel shaft is 88mm from the ground. Then tighten all the Nyloc Nuts.

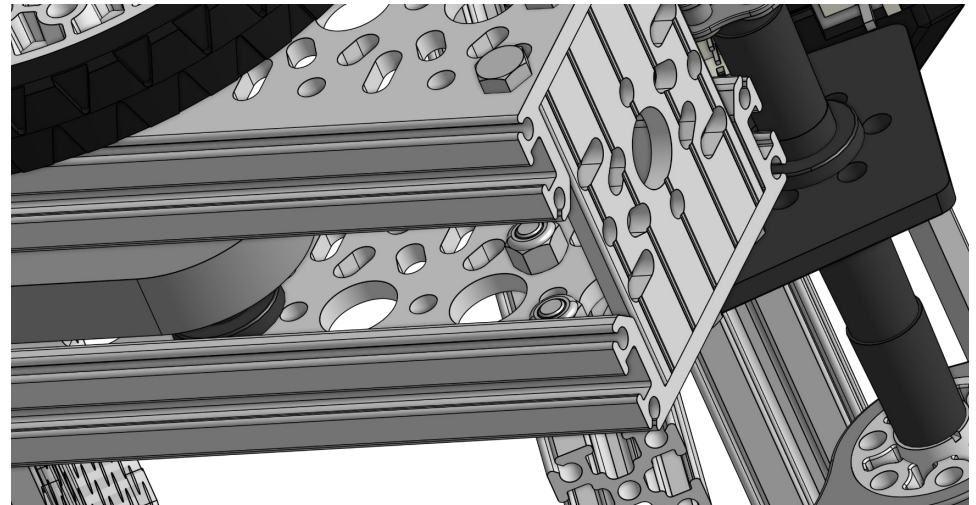
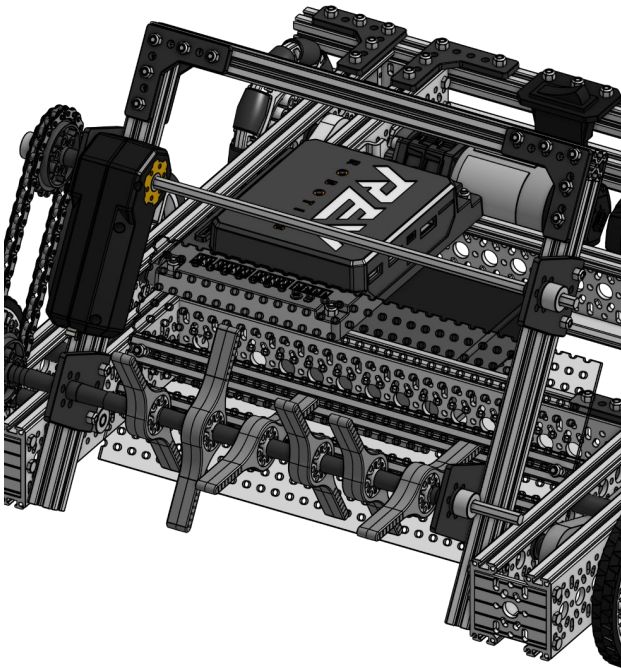



2026-27 REV DUO FTC Starter Bot Base Build Guide

