

#25 PLASTIC SPROCKETS

PART NUMBER	TOOTH	PITCH DIAMETER X (IN)	PITCH DIAMETER Y (MM)	O.D. (W/CHAIN) A (IN)	O.D. (W/CHAIN) B (MM)
REV-41-1338	10	0.80	20.2	0.95	24.1
REV-41-1339	15	1.20	30.5	1.45	36.9
REV-41-1340	20	1.60	40.6	1.85	46.9
REV-41-1342	26	2.07	52.7	2.32	59.0
REV-41-1343	40	3.19	80.9	3.43	87.3
REV-41-1341	54	4.30	109.2	4.55	115.6

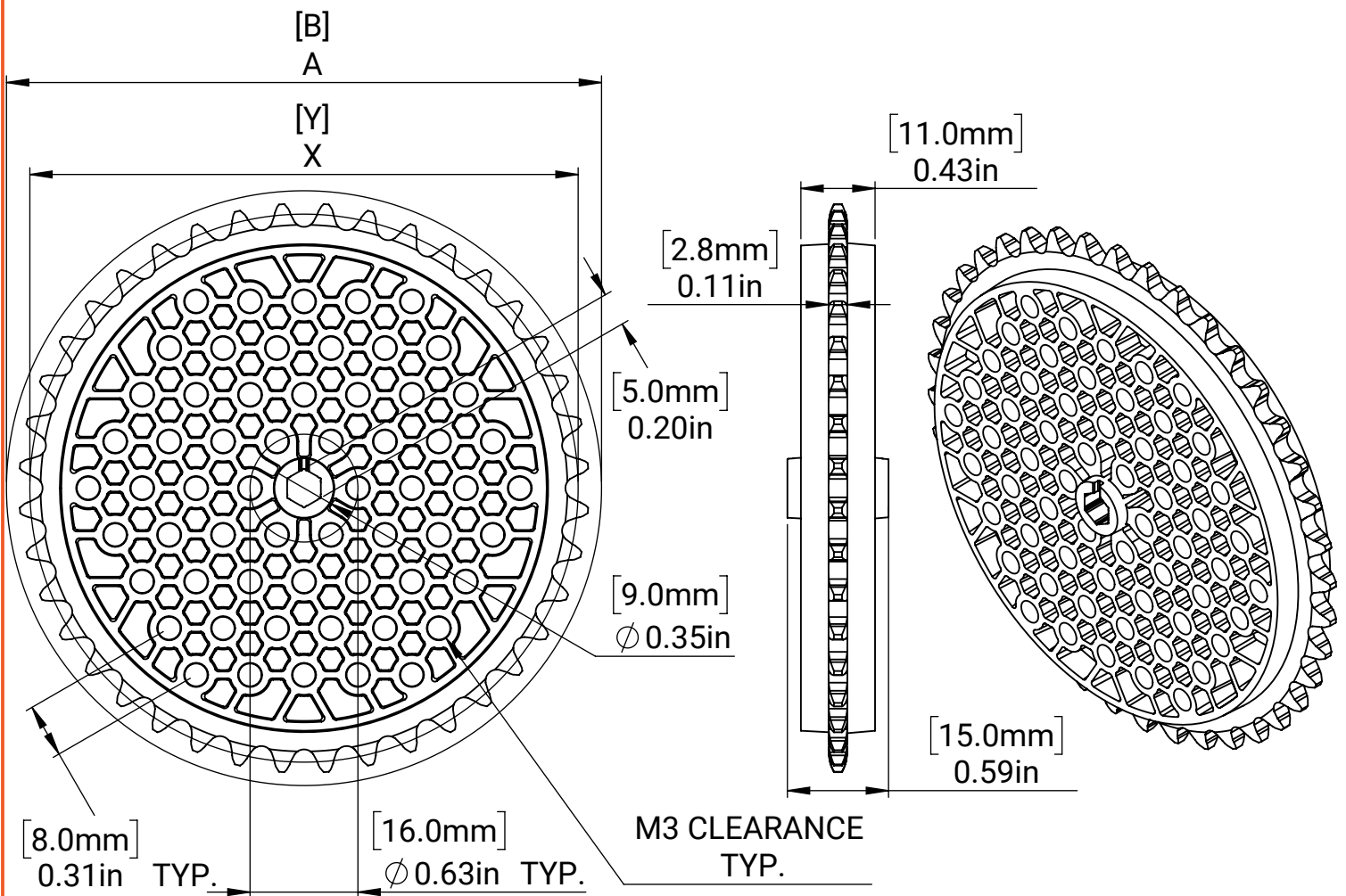

MM SHEET TOLERANCES:
 X ± 0.50 MM
 X.X ± 0.10 MM
 X.XX ± 0.05 MM
 ANGLES ± 2°

INCH SHEET TOLERANCES:
 X ± 0.1 IN
 X.X ± 0.02 IN
 X.XX ± 0.004 IN
 X.XXX ± 0.002 IN
 ANGLES ± 2°

MATERIAL:
ACETAL

DATE: 7/31/2020