

METAL PLATE SPROCKETS

PART NUMBER	TOOTH	PITCH DIAMETER X (IN)	PITCH DIAMETER Y (MM)	O.D. (W/ CHAIN) A (IN)	O.D. (W/ CHAIN) B (MM)
REV-41-1717	15	1.20	30.5	1.45	36.9
REV-41-1720	20	1.60	40.6	1.85	46.9
REV-41-1721	26	2.07	52.7	2.32	59.0
REV-41-1722	32	2.55	64.8	2.80	71.1
REV-41-1723	40	3.19	80.9	3.43	87.3
REV-41-1724	48	3.82	97.1	4.07	103.4
REV-41-1725	54	4.30	109.2	4.55	115.6

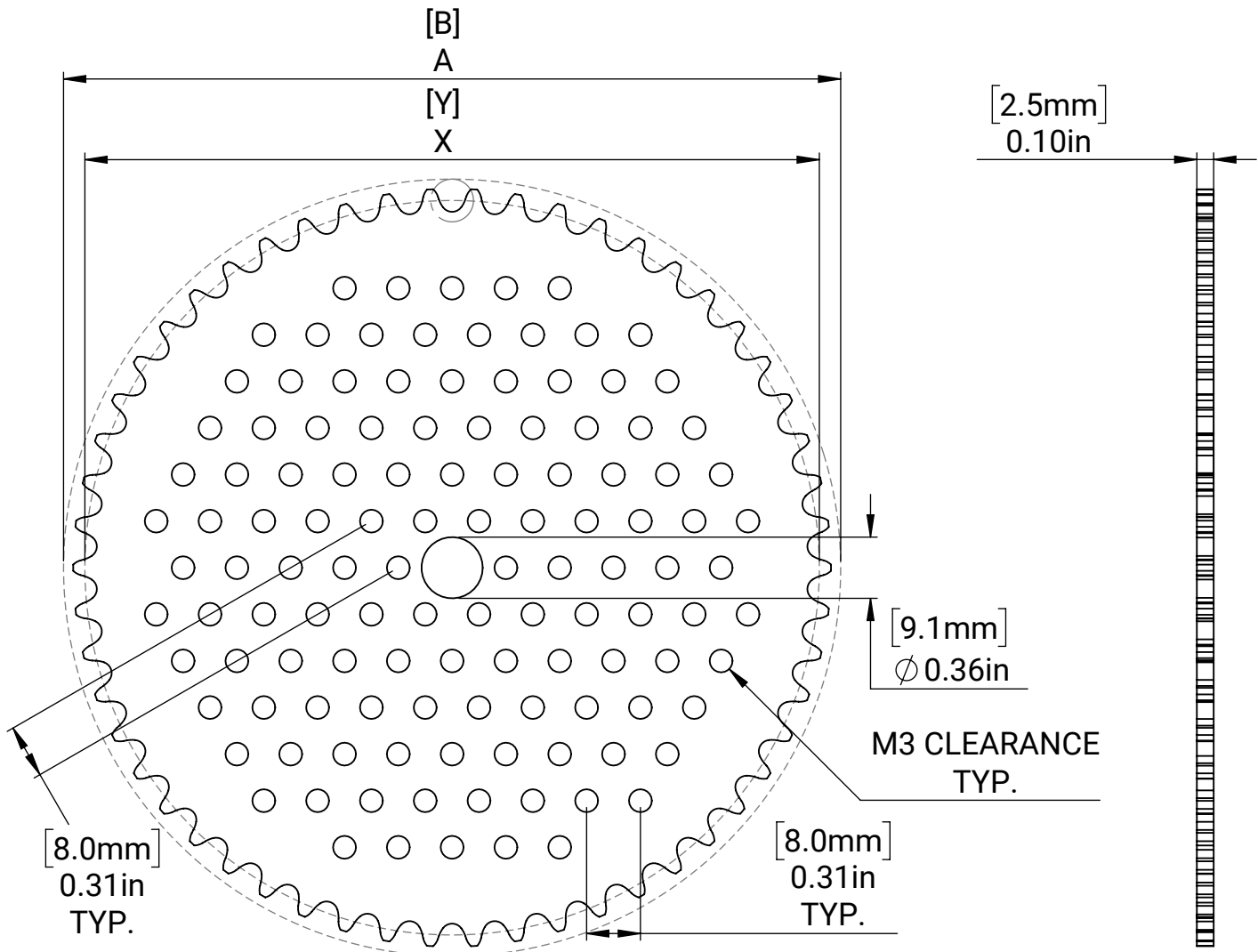

MM SHEET TOLERANCES:
 X \pm 0.50 MM
 X.X \pm 0.10 MM
 X.XX \pm 0.05 MM
 ANGLES \pm 2°

INCH SHEET TOLERANCES:
 X \pm 0.1 IN
 X.X \pm 0.02 IN
 X.XX \pm 0.004 IN
 X.XXX \pm 0.002 IN
 ANGLES \pm 2°

MATERIAL:
6063-T6 aluminum

DATE: 7/31/2020