

10 TOOTH METAL #25 SPROCKET

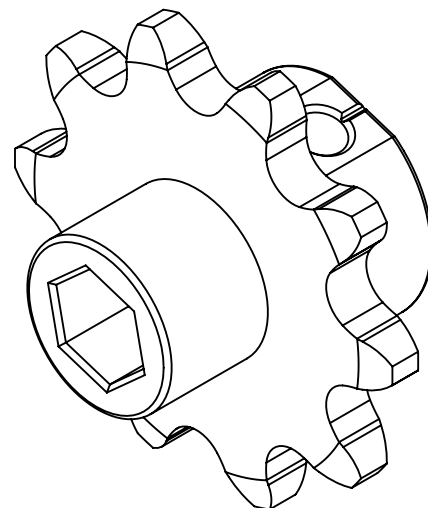
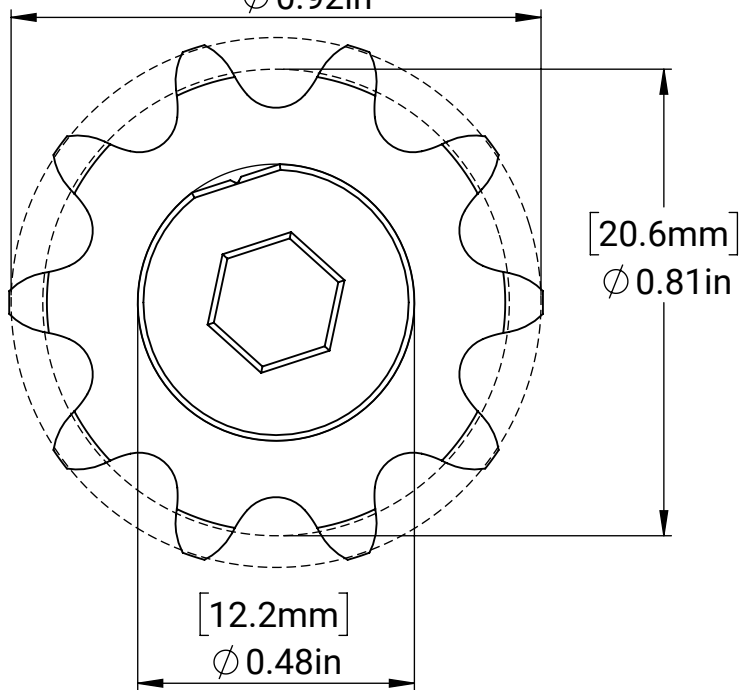
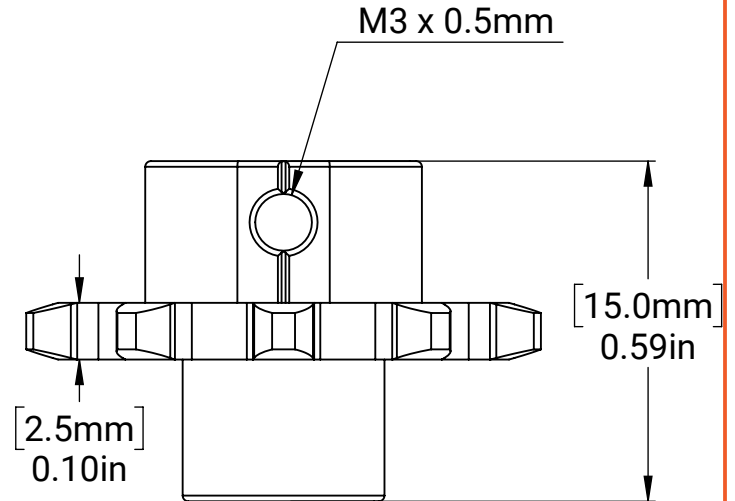
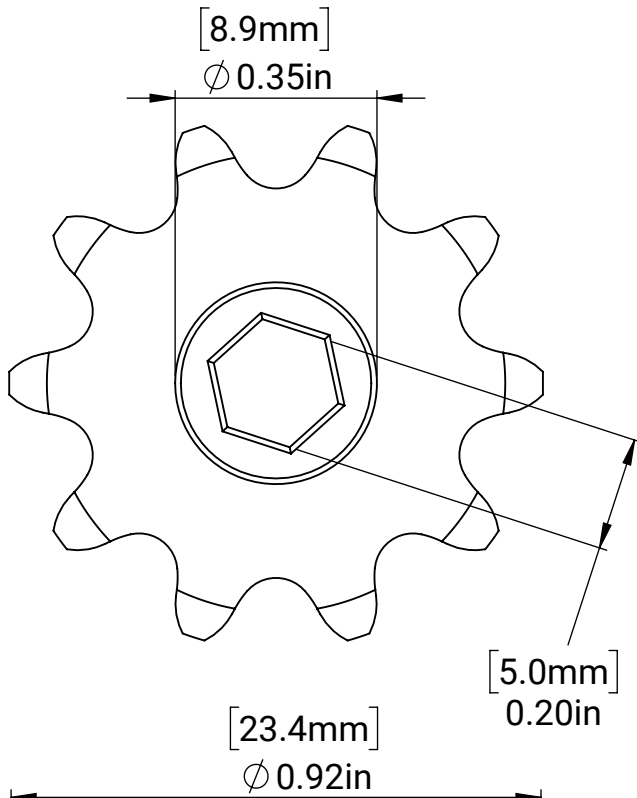

MM SHEET TOLERANCES:

X ± 0.50 MM
 X.X ± 0.10 MM
 X.XX ± 0.05 MM
 ANGLES $\pm 2^\circ$

INCH SHEET TOLERANCES:

X ± 0.1 IN
 X.X ± 0.02 IN
 X.XX ± 0.004 IN
 X.XXX ± 0.002 IN
 ANGLES $\pm 2^\circ$

MATERIAL:

STEEL

DATE: 7/31/2020