

## 75MM MECANUM WHEEL - RIGHT

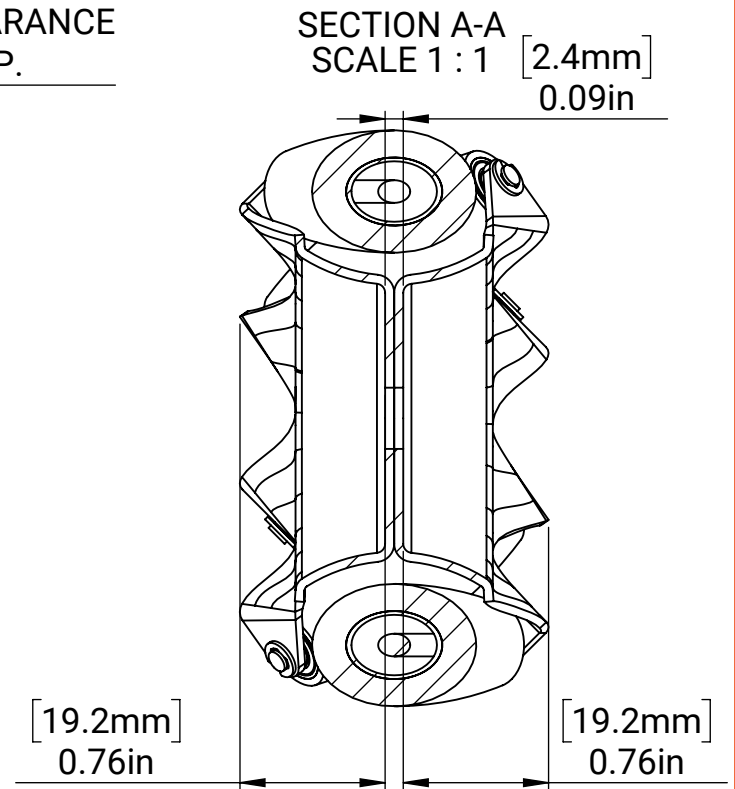
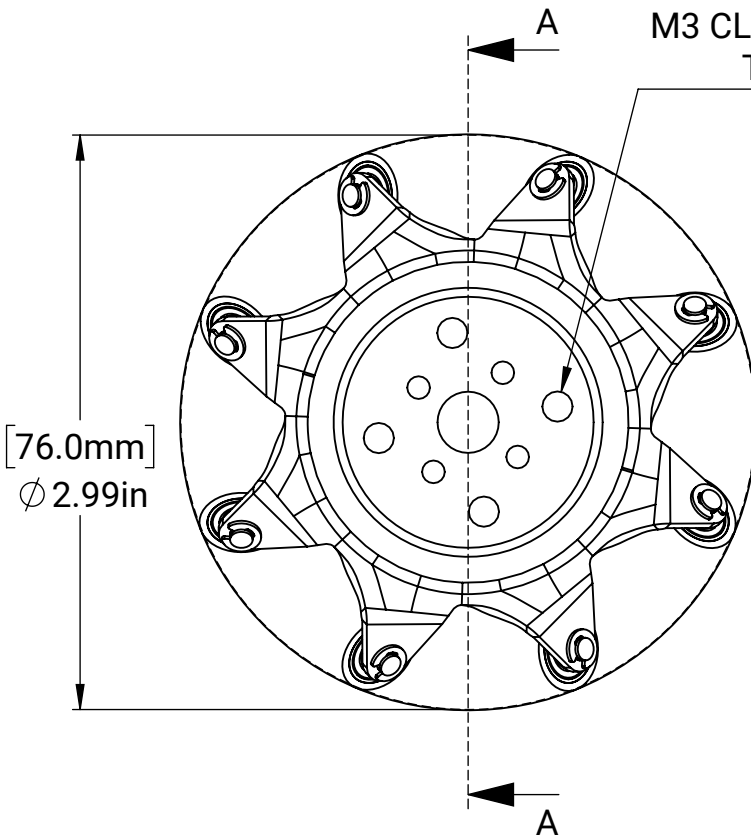
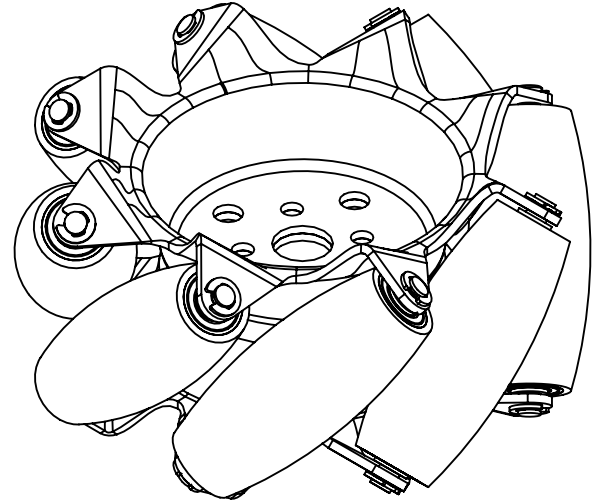
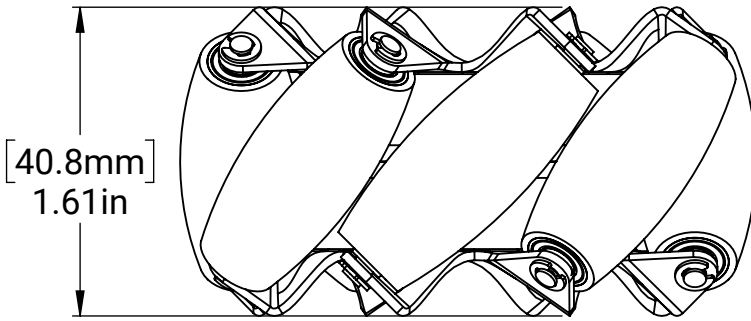

MM SHEET TOLERANCES:

X ± 0.50 MM  
X.X ± 0.10 MM  
X.XX ± 0.05 MM  
ANGLES ± 2°

INCH SHEET TOLERANCES:

X ± 0.1 IN  
X.X ± 0.02 IN  
X.XX ± 0.004 IN  
X.XXX ± 0.002 IN  
ANGLES ± 2°

MATERIAL:

DATE: 7/31/2020