

#25 NEO PINION SPROCKET - 10 TOOTH

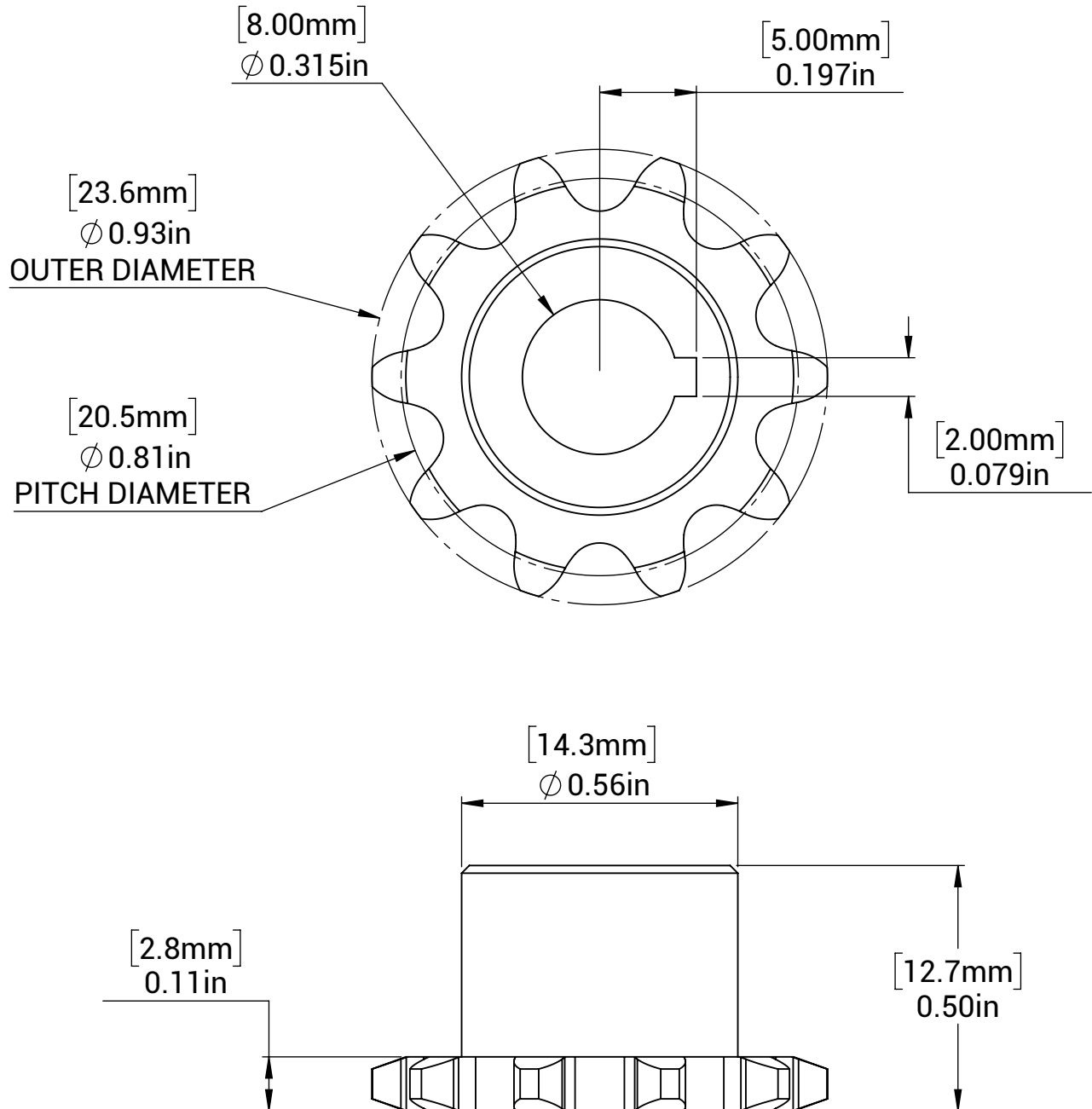

MM SHEET TOLERANCES:

X \pm 0.50 MM
 X.X \pm 0.10 MM
 X.XX \pm 0.05 MM
 ANGLES \pm 2°

INCH SHEET TOLERANCES:

X \pm 0.1 IN
 X.X \pm 0.02 IN
 X.XX \pm 0.004 IN
 X.XXX \pm 0.002 IN
 ANGLES \pm 2°

MATERIAL:

STEEL

DATE: 2/8/2021