

15MM PLASTIC GEARS

| PART NUMBER | TEETH | X (IN) | Y (MM) | A (IN) | B (MM) |
|-------------|-------|--------|--------|--------|--------|
| REV-41-1331 | 15 | 0.50 | 12.7 | 0.35 | 11.25 |
| REV-41-1332 | 30 | 0.95 | 24.0 | 0.89 | 22.5 |
| REV-41-1333 | 125 | 3.75 | 93.5 | 3.69 | 93.75 |
| REV-41-1334 | 45 | 1.39 | 35.3 | 1.33 | 33.75 |
| REV-41-1335 | 60 | 1.83 | 46.5 | 1.77 | 45 |
| REV-41-1336 | 72 | 2.19 | 55.5 | 2.13 | 54 |
| REV-41-1337 | 90 | 2.72 | 69.0 | 2.66 | 67.5 |

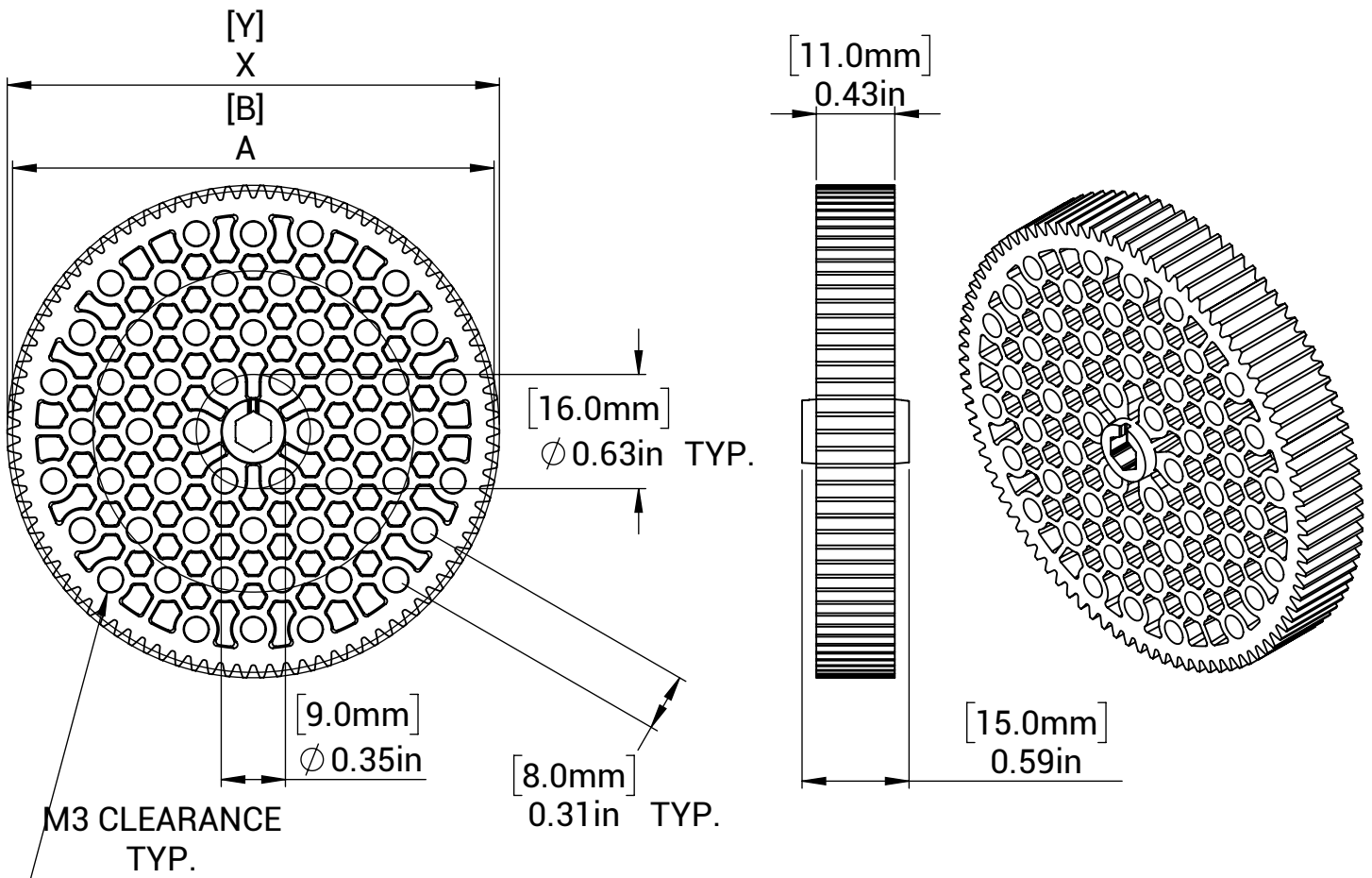

MM SHEET TOLERANCES:

X ± 0.50 MM
 X.X ± 0.10 MM
 X.XX ± 0.05 MM
 ANGLES $\pm 2^\circ$

INCH SHEET TOLERANCES:

X ± 0.1 IN
 X.X ± 0.02 IN
 X.XX ± 0.004 IN
 X.XXX ± 0.002 IN
 ANGLES $\pm 2^\circ$

MATERIAL:

ACETAL

DATE: 4/6/2021