

REV

ROBOTICS

EXPANSION HUB GUIDE



TABLE OF CONTENTS

| | | |
|-------|---|----|
| 1 | OVERVIEW..... | 1 |
| 1.1 | Expansion Hub Basics | 1 |
| 1.2 | Port Pin Outs | 2 |
| 1.3 | Protection Features | 3 |
| 1.4 | Cables and Connectors..... | 3 |
| 1.4.1 | XT30 – Power Cable..... | 3 |
| 1.4.2 | JST VH – Motor Power | 4 |
| 1.4.3 | JST PH – Sensors and RS485..... | 5 |
| 2 | QUICK START | 7 |
| 2.1 | Required Materials | 7 |
| 2.2 | System Wiring Diagram..... | 8 |
| 2.3 | Driver Station and Robot Controller Pairing | 8 |
| 2.4 | Robot Configuration..... | 8 |
| 2.5 | Adding an Additional Expansion Hub | 12 |
| 2.6 | LED Blink Codes | 15 |
| 3 | INTEGRATED SENSORS | 17 |
| 4 | LEGACY SENSOR SUPPORT | 17 |
| 4.1 | Level Shifter | 17 |
| 4.2 | Connecting a 5V Motor Encoder | 18 |
| 4.3 | Connecting a 5V Sensor | 18 |
| 4.4 | Sensor Compatability Chart | 19 |
| 5 | Dimensions | 22 |

1 OVERVIEW

1.1 Expansion Hub Basics

The REV Robotics Expansion Hub is a low-cost education device that can communicate with any computer (Commonly an Android Phone or the REV Robotics Control Hub) to provide the interfaces required for building robots and other mechatronics. The Expansion Hub was purposely built to stand up to the rigors of the classroom and competition field. It features a mature firmware designed for basic and advanced use cases with the ability to be field upgraded in the future.

The REV Robotics Expansion hub is an approved device for use in the **FIRST** Tech Challenge and **FIRST** Global.

- **Physical Dimensions**
 - 143mm X 103mm X 29.5 mm
 - Mounting holes on a 16mm spacing
- **Input Voltage:**
 - 12V Nominal (8-15VDC)
- **3.3V Ports**
 - **8x Digital I/O:** 1A Source Max
 - **4x I2C 100kHz/400kHz Busses:** 500mA Max
 - **4x 12-bit Analog Inputs:** 500mA Max
 - **4x Quadrature Encoder Inputs:** 500mA Max
- **5V Ports**
 - **5V Aux Power:** 2A Max
 - **Servos:** 2A Maximum per Pair
 - **USB 2.0:** 1.5A Max

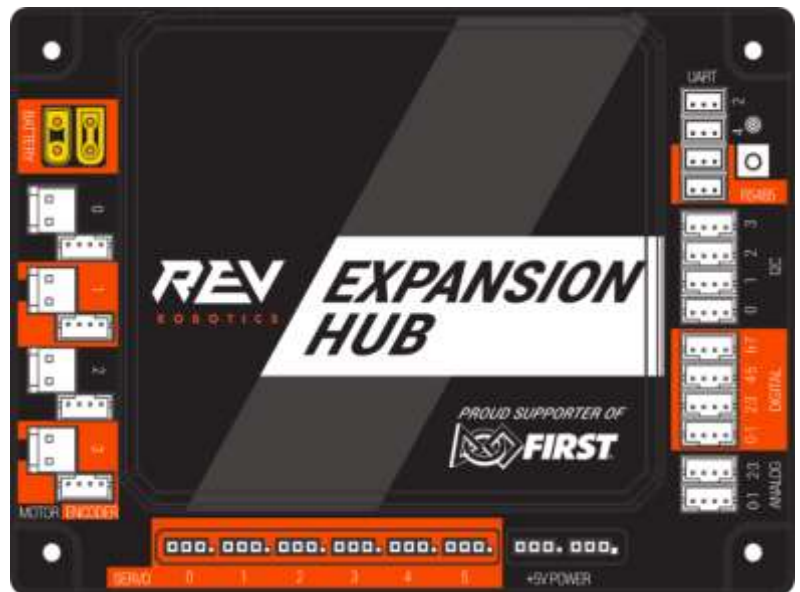

| PORT | QTY | CONNECTOR | DESCRIPTION |
|--------------|-----|---------------|---|
| Battery | 2 | XT30 | Connect one 12V NiMh battery, use the second connector to add another Expansion Hub |
| Motor | 4 | JST VH, 2-pin | Motor power output |
| Encoder | 4 | JST PH, 4-pin | Quadrature encoder input |
| Servo | 6 | 0.1" Header | Extended range 5V servo output (500-2500ms) |
| 5V Aux Power | 2 | 0.1" Header | Auxiliary device 5V/2A |
| Analog | 4 | JST PH, 4-pin | Analog input 0-3.3V with two channels per connector |
| Digital | 8 | JST PH, 4-pin | Digital Input/Output with two channels per connector |
| I2C | 4 | JST PH, 4-pin | Four separate I2C busses, 400kHz bus speed |
| RS485 | 2 | JST PH, 3-pin | Use this serial communication port to add another Expansion Hub |
| UART | 2 | JST PH, 3-pin | Debugging only |
| USB | 1 | Mini Type | Connect directly to the Robot Controller Android phone or PC |

1.2 Port Pin Outs

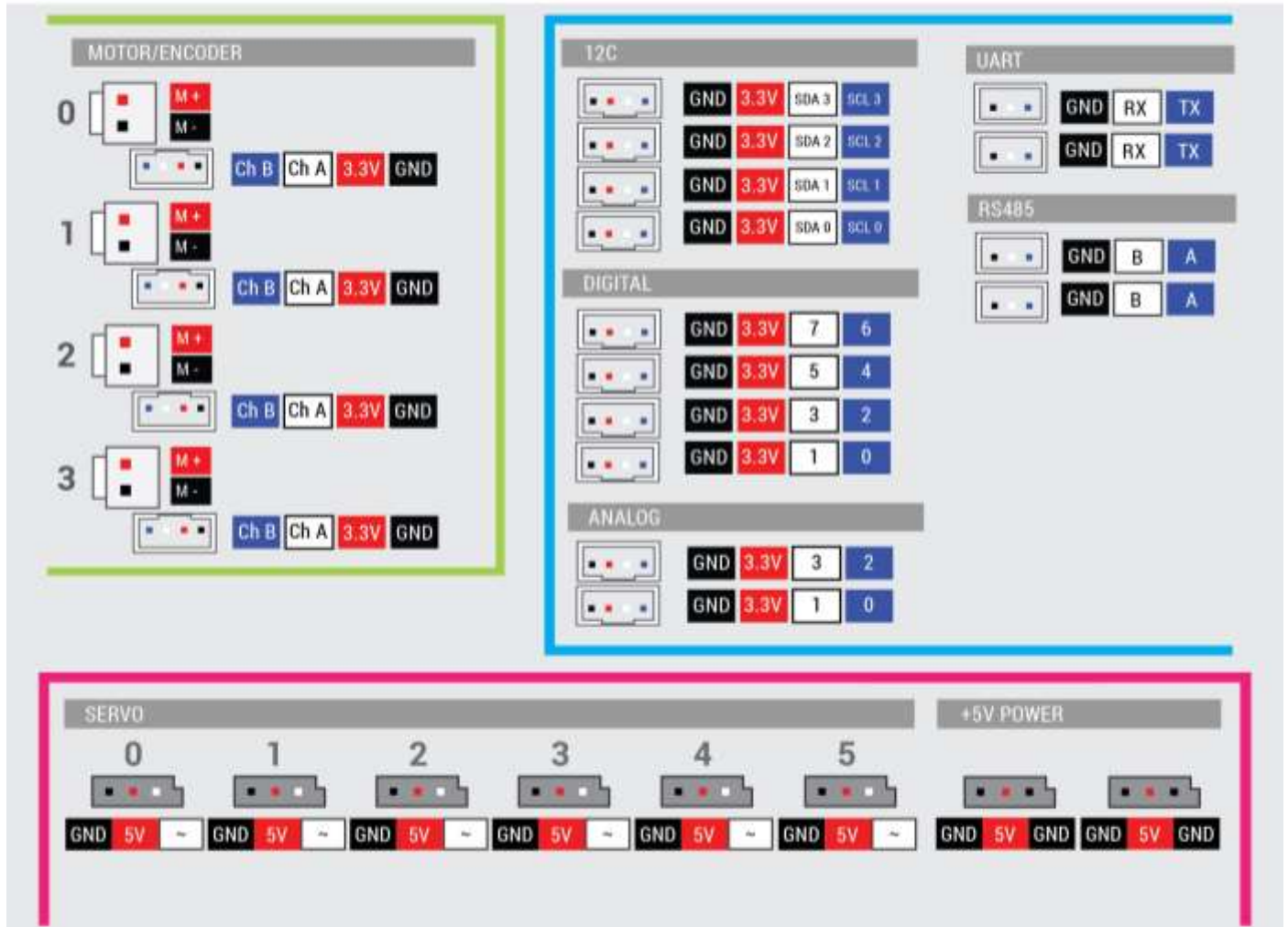
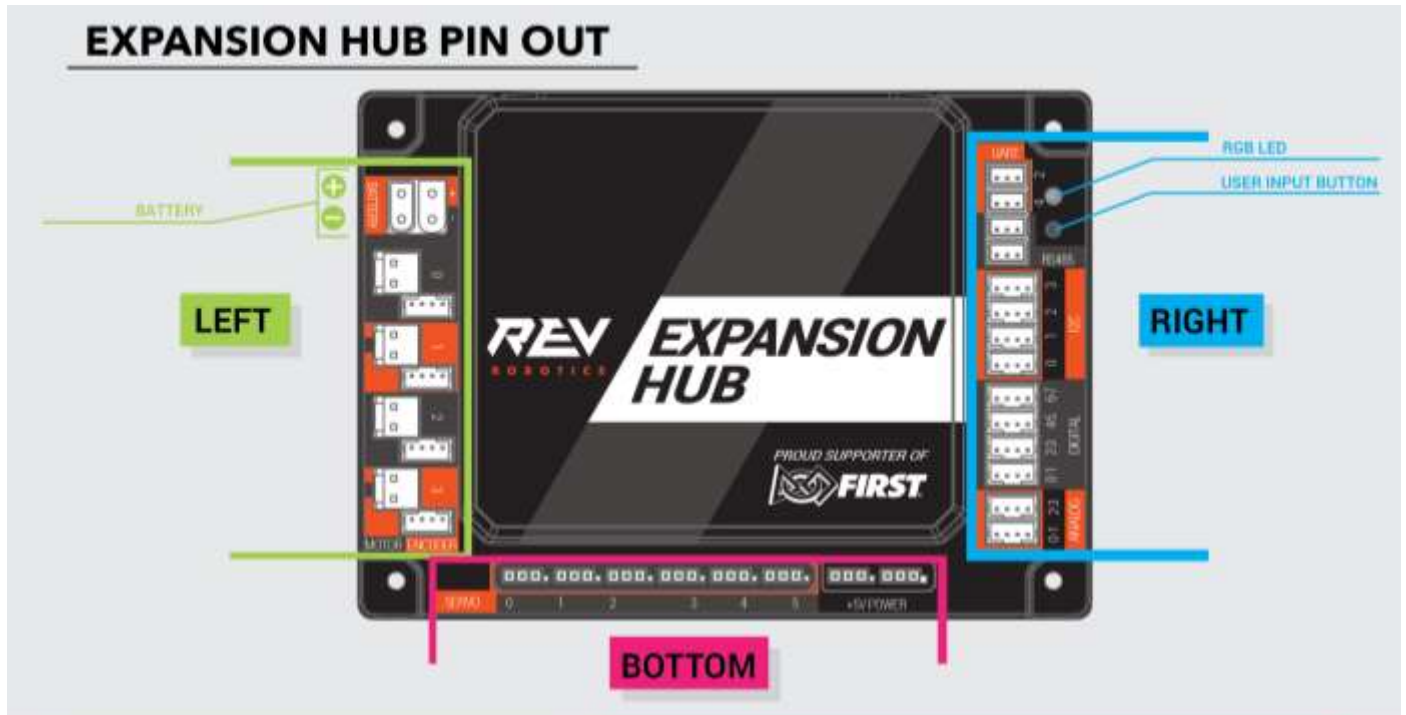

1.3 Protection Features

- Reverse Battery Input Protection
- ESD Protection on all Connections
- Overcurrent PTC Protection
 - Digital I/O Bus
 - I2C Bus
 - Analog Bus
 - USB
 - Servos per Channel Pair
 - Encoder Bus
- Over Current Monitoring for individual Motor Channels
- Keyed and Locking Connectors
- Failsafe Mode at Communication Loss

1.4 Cables and Connectors

The REV Robotics Expansion Hub connector selection provides robust high-density solution for FTC teams. All connectors are keyed and locking with the exception of the Servo, 5V auxiliary power, and Mini USB ports.

1.4.1 XT30 – Power Cable

The XT30 connector is used for connecting a battery and powering a second Expansion Hub. Each Expansion Hub has both a Male and Female XT30 connector. The connectors are tied together internally so it does not matter which is power in or out, but the standard convention is that the male connector is the power in side.

Most teams will want to use premade cables which can be sources from the REV Robotics website directly (Table 1) for convenience, but teams can also make their own cables. These connectors are solder cup style and do not require any crimping tools; connectors are available from various online vendors. These connectors are an open design so they are manufactured by a variety of sources and quality may vary. AMASS branded connectors are recommended, but there are many other quality vendors available.

Table 1: Premade XT30 Cables and Accessories

| | Length | REV Robotics Part Number |
|--|--------|--------------------------|
| XT30, Male - XT30, Female | 20cm | REV-31-1391 |
| XT30, Male - XT30, Female | 30cm | REV-31-1392 |
| XT30, Male - XT30, Female | 50cm | REV-31-1393 |
| XT30, Female - Tamiya | 8cm | REV-31-1382 |
| XT30, Female - Anderson Power Pole Style | 8cm | REV-31-1385 |
| Power Switch Cable (XT30 Male – XT30 Female) | | REV-31-1387 |
| XT30 Connector Pack – 5 Pairs | - | REV-31-1399 |

1.4.2 JST VH – Motor Power

Motor Power connections on the Expansion Hub use the JST VH style connector. This connector is keyed and locking with a small latch (Figure 1) which must be depressed to release the cable.



Figure 1: How to Use a JST VH Cable

REV Robotics recommends in most cases that teams use pre-made cables because the quality of the crimp is better when made using industrial tooling. These cables can be bought directly from the REV Robotics Website (Table 2) or through other online vendors.

Table 2: Premade JST VH Cables and Accessories

| | Pins | Length | REV Robotics Part Number |
|-----------------------------------|--------|--------|--------------------------|
| JST VH - JST VH | 2 pins | 20cm | REV-31-1411 |
| JST VH - JST VH | 2 pins | 30cm | REV-31-1412 |
| JST VH - JST VH | 2 pins | 50cm | REV-31-1413 |
| JST VH - Anderson Power Pole Type | 2 pins | 12cm | REV-31-1381 |
| JST VH Cable Extension Board | 2 pins | | REV-31-1429 |

For teams which would like more information regarding the connectors or to try crimping their own cables, Table 3 lists the appropriate part numbers.

Connector Specifications

- 10A Continuous Current (16AWG)
- 3.96mm Pitch
- Accepts 22-16AWG Wire

Table 3: JST VH Connector Part Number Reference

| | Manufacturer Part Number | DigiKey Part Number |
|-----------------------------------|--------------------------|-------------------------------|
| Contact, JST VH, 18-22AWG | SVH-21T-P1.1 | 455-1133-1-ND |
| Contact, JST VH, 16-20AWG | SVH-41T-P1.1 | 455-1319-1-ND |
| Housing, JST VH, 2-pin | VHR-2N | 455-1183-ND |
| Header, JST VH, 2-pin, Top Entry | B2P-VH | 455-1639-ND |
| Header, JST VH, 2-pin, Side Entry | B2PS-VH | 455-1648-ND |

Connector Datasheet: <http://www.jst-mfg.com/product/pdf/eng/eVH.pdf>

1.4.3 JST PH – Sensors and RS485

The JST PH style connector is used for motor encoder, analog, digital, I2C, RS485, and UART connections on the Expansion Hub. These are all 4-pin connections except for the RS485 and UART which are 3 pin. The connectors are keyed (they only insert in one orientation) and are friction locking. In Figure 2 the keying feature aligned with the cable is shown.

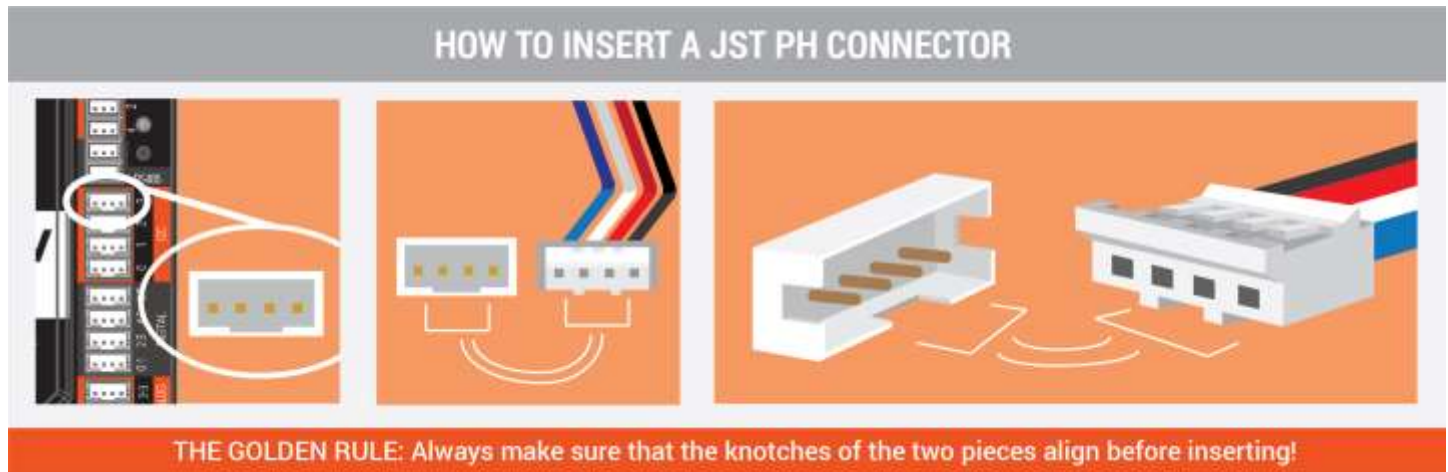

Figure 2: How to Use a JST PH Cable

REV Robotics recommends in most cases that teams use pre-made cables because the quality of the crimp is better when made using industrial tooling. These cables can be bought directly from the REV Robotics Website (Table 4 and Table 5) or through other online vendors.

Table 4: Premade 4-pin JST PH Cables and Accessories

| | Pins | Length | REV Robotics Part Number |
|------------------------------|--------|--------|--------------------------|
| JST PH - JST PH | 4 pins | 20cm | REV-31-1406 |
| JST PH - JST PH | 4 pins | 30cm | REV-31-1407 |
| JST PH - JST PH | 4 pins | 50cm | REV-31-1408 |
| JST PH Cable Extension Board | 4 pins | | REV-31-1388 |

Table 5: Premade 3-pin JST PH Cables

| | Pins | Length | REV Robotics Part Number |
|-----------------|--------|--------|--------------------------|
| JST PH - JST PH | 3 pins | 20cm | REV-31-1416 |
| JST PH - JST PH | 3 pins | 30cm | REV-31-1417 |
| JST PH - JST PH | 3 pins | 50cm | REV-31-1418 |

For teams which would like more information regarding the connectors or to try crimping their own cables, Table 6 lists the appropriate part numbers.

Connector Specifications

- 2A Continuous Current (24AWG)
- 2.0mm Pitch
- Accepts 32-24AWG Wire

Table 6: JST PH Connector Part Number Reference

| | Manufacturer Part Number | DigiKey Part Number |
|-----------------------------------|---------------------------------|-------------------------------|
| Contact, JST PH, 30-24AWG | SPH-002T-P0.5S | 455-1127-1-ND |
| Contact, JST PH, 28-24AWG | SPH-002T-P0.5L | 455-2148-1-ND |
| Housing, JST PH, 4-pin | PHR-4 | 455-1164-ND |
| Header, JST PH, 4-pin, Top Entry | B4B-PH-K-S | 455-1706-ND |
| Header, JST PH, 4-pin, Side Entry | S4B-PH-K-S | 455-1721-ND |
| Housing, JST PH, 3-pin | PHR-3 | 455-1126-ND |
| Header, JST PH, 3-pin, Top Entry | B3B-PH-K-S | 455-1705-ND |
| Header, JST PH, 3-pin, Side Entry | S3B-PH-K-S | 455-1720-ND |

Connector Datasheet: <http://www.jst-mfg.com/product/pdf/eng/ePH.pdf>

2 QUICK START

2.1 Required Materials



Expansion Hub
REV-31-1153



12V NiMh Slim Battery *
REV-31-1302



Properly Configured Driver Station (DS)
and Robot Controller (RC) Phones *



USB Game Pad *



USB A Female to Micro USB *
REV-31-1426

* Other FTC legal part numbers exist.

Optional Additional Materials needed to [Connect an Additional Expansion Hub](#):

- Expansion Hub (REV-31-1153)
- XT30 Extension Cable
- Communication Cable (RS-485)

2.2 System Wiring Diagram

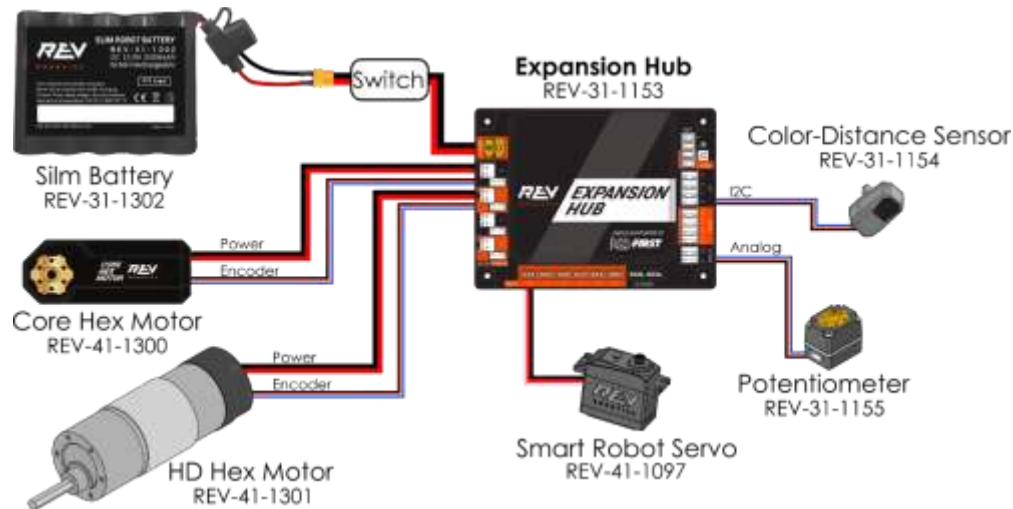

Figure 3: System Wiring Diagram

2.3 Driver Station and Robot Controller Pairing

NOTE: You should update your Driver Station(DS) and Robot Controller(RC) phones to the latest app version in order to use the new Expansion Hub controller. The minimum compatible version is 3.1 released on May 10th, 2017

Please ensure that the Driver Station and Robot Controller phones are properly configured and paired. Refer to the latest pairing and troubleshooting instructions provided by in the [FTC Control System Wiki](#).

2.4 Robot Configuration

Every device connected to the Expansion Hub will need to be added to the Robot Configuration file before you can use the device in your program. The Robot Configuration will allow you to give your sensors and actuators meaningful names that you can reference while programming.

For this example, we will configure a simple two motor robot drivetrain (Figure 4).

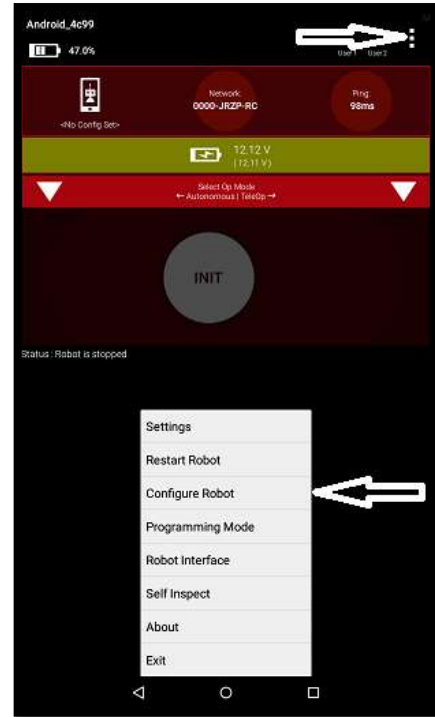

Figure 4: The miniBot is a Simple 2-Motor Robot

Configuring Your Robot for the First Time

2.4-1. Connect your Robot Controller Phone via USB to the Expansion Hub's mini USB port. It's also recommended to connect a battery.

2.4-2. Select the menu on either the Driver Station or Robot Controller. Then select "Configure Robot".



2.4-3. Select "New" in the top left hand corner.



2.4-4. Select "Expansion Hub Portal 1".

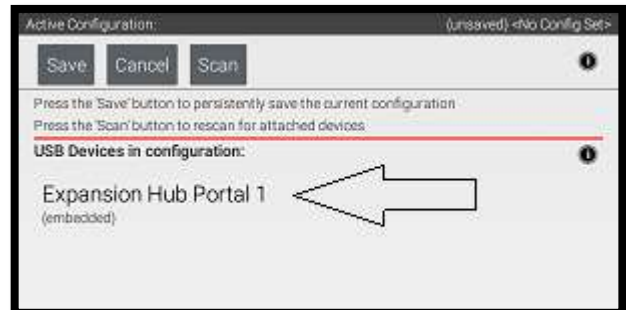

2.4-5. Select "Expansion Hub 1".

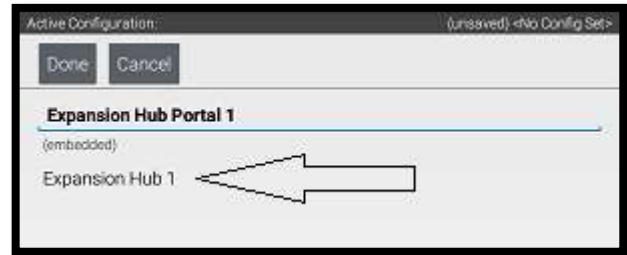

2.4-6. Select "Motors".

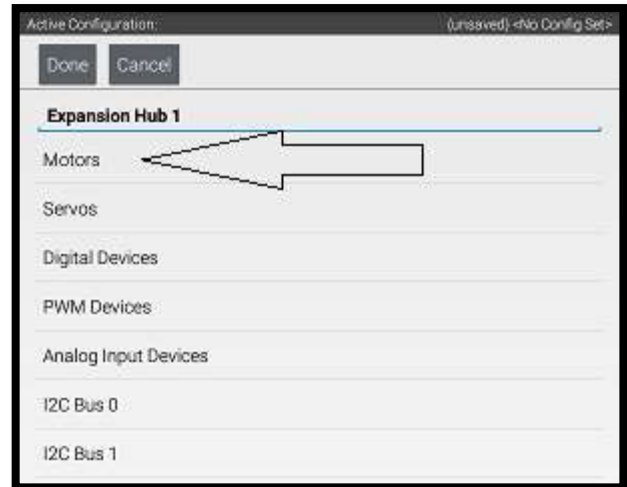

2.4-7. Select the Drop Down menu for "Port 0" then select the motor type attached to the port. In the case of the Minibot in Figure 4, select the "Rev Robotics Core Hex Motor".



2.4-8. Press "Enter motor name here" and name the motor "left_drive".

This is the name that you will use when you are programming your robot to control this motor. Always use descriptive names so that you can remember what a device does when you are programming.

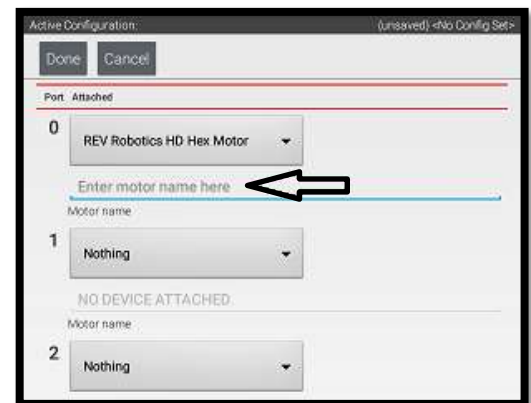

2.4-9. Repeat the process for “Port 1” and name the motor “right_drive”.

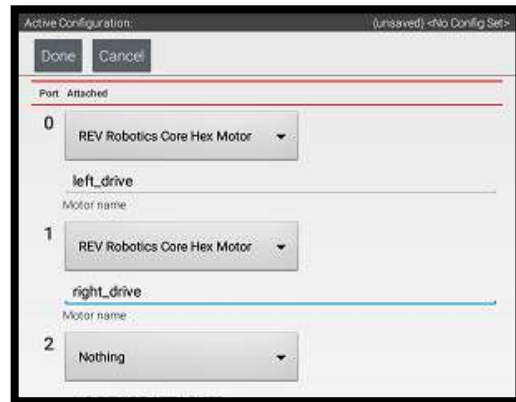

2.4-10. Press done once to go back to the list of device port and then select I2C Bus 0.



2.4-11. Add the built-in REV Expansion Hub IMU. Name it “imu”

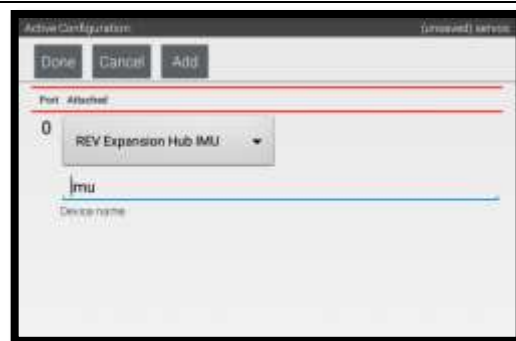

2.4-12. Press the “Done” button (at the top left corner of the page) 3 times.



2.4-13. Press "Save".

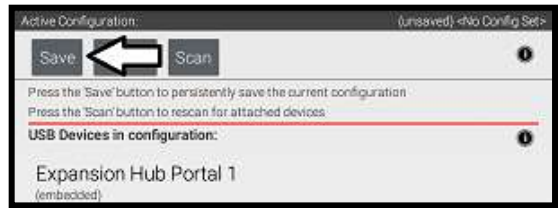

2.4-14. Enter "miniBot" as your configuration name, then select "OK".

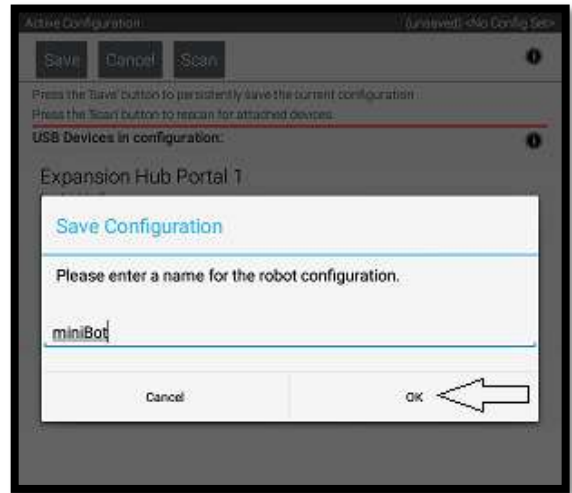

2.4-15. You now have an active configuration called "miniBot". Press the Android back button to return to the Driver Station page.



2.5 Adding an Additional Expansion Hub

If you want to use more than 4 motors or 6 servos, you will need to add the Expansion Hub to your robot. An Expansion Hub can be added to another Expansion Hub or to a Control Hub. The Expansion Hub has all of the same ports as the Control Hub but without the wireless capability.

| <i>Control Hub vs Expansion Hub in FIRST</i> | |
|--|--|
| FIRST Tech Challenge | FIRST Global |
| Teams in FTC can use up to two (2) Expansion Hubs and an Android Phone in their robots starting in the 2017-2018 season. Read the official FTC Game Manuals for complete game rules. | FIRST Global teams must use one (1) Control Hub and may add one (1) Expansion Hub to their robot. Read the official FIRST Global manual for complete game rules. |

Adding an Expansion Hub to your Robot

- 2.5-1. To add an additional Expansion Hub to your robot, each hub must have a unique address. Expansion Hubs come from the factory with the default address: 2.

With the Robot Controller Phone connected via USB to the Expansion Hub and no other Expansion Hubs Connected, select the menu on either the Driver Station or Robot Controller. Then select “Settings” and “Advanced Settings”.

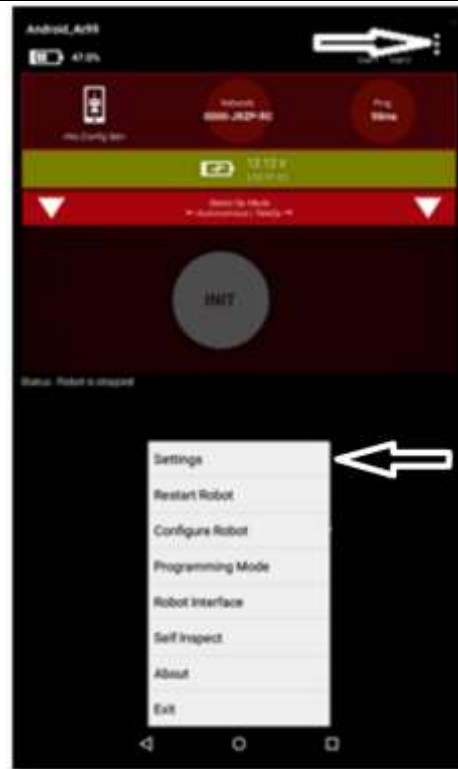

- 2.5-2. In Advanced Settings, select “Expansion Hub Address Change”

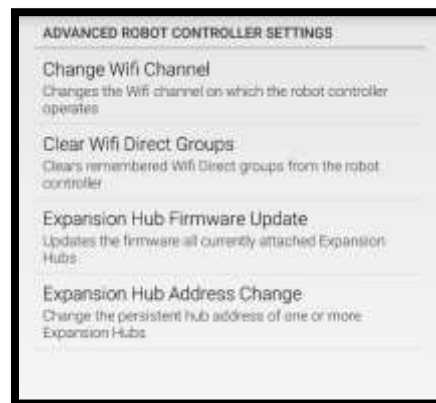

- 2.5-3. Use the drop-down Menu to change the address. Select a number other than 2 and then back out of the menu using the triangle button.

Once you are back at the main app screen, Power cycle the Expansion Hub by unplugging the phone and battery (if used).

Reconnect the phone and battery.

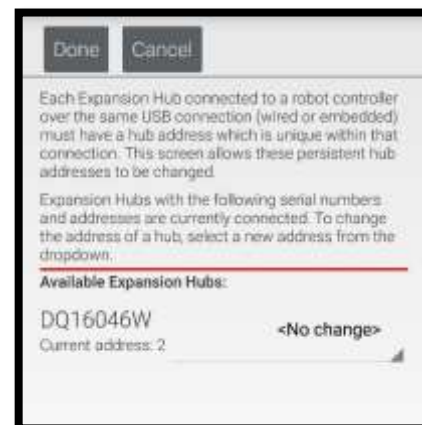

2.5-4. Use the XT30 Extension Cable to connect power between the two Expansion Hubs.

2.5-5. Use the 3-pin JST PH cable and the RS485 port to connect communication between the two Expansion Hubs.

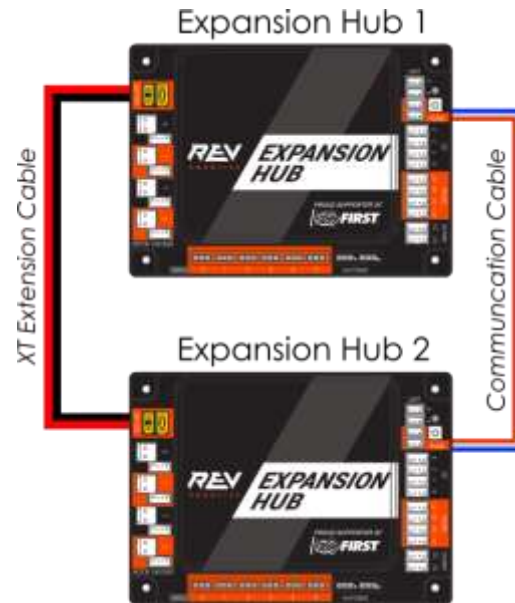

2.5-6. From the Driver Station or Robot Controller app choose “Configure Robot”

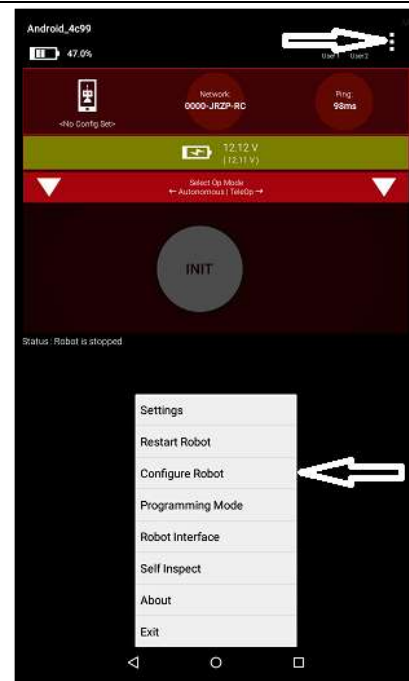

2.5-7. Select “New” in the top left hand corner.

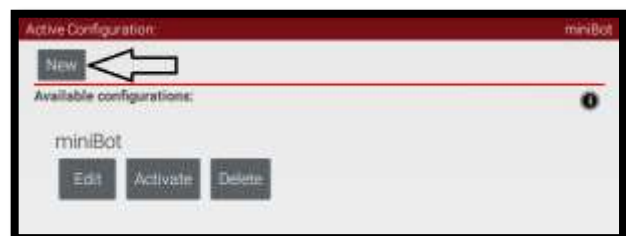

2.5-8. Select "Expansion Hub Portal 1"

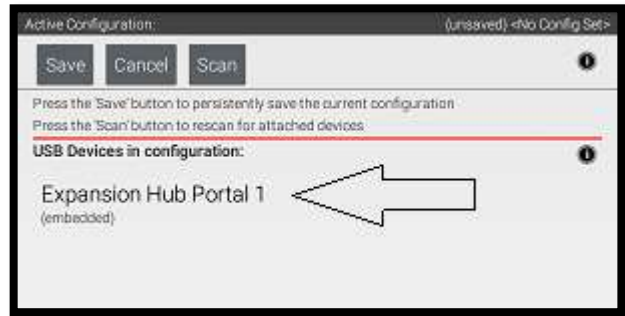

2.5-9. Now you have 2 Hubs to choose from. Configure and program as necessary.

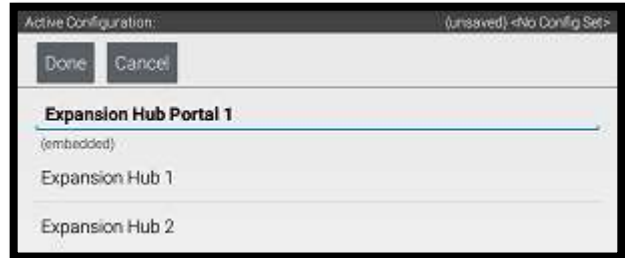

2.6 LED Blink Codes

The RGB LED located on the Expansion Hub near the RS485 ports provides user feedback regarding the status of the Expansion Hub. Reference Table 7 and Table 8 for different firmware LED codes.

Table 7: Firmware Version 1_06_00 LED Codes











| Firmware Version 1_06_00 | | | |
|---|---|---------|---|
| LED Status | LED Description | When | Hub Status |
|  | Solid Blue | At Boot | Expansion Hub has power; either 12V from the battery or 5V sourced from the phone and is waiting to initialize communications. |
|  | Solid Blue | Anytime | Hub is waiting for communication with the Driver Station Host. Expansion Hub has power; either 12V from the battery or 5V sourced from the phone. |
|  | Solid Green with one or more blue blinks every ~5 Seconds | Anytime | Hub has power and active communication with the Android Platform. The number of blue blinks is the same as the Hub's address. The factory default address is 2 (). |

Table 8: Firmware Version 1_07_00 LED Codes

| Firmware Version 1_07_00 | | | |
|---|---|---------|---|
| LED Status | LED Description | When | Hub Status |
|  | Solid Blue | At Boot | Expansion Hub has power; Battery is >7V and is waiting to initialize communications. |
|  | Solid Blue | Anytime | Hub is waiting for communication with the Driver Station Host. Expansion Hub has power; Battery is >7V. |
|  | Solid Green with one or more blue blinks every ~5 Seconds | Anytime | Hub has power and active communication with the Android Platform. The number of blue blinks is the same as the Hub's address. The factory default address is 2 (). |
|  | Blinking Blue | Anytime | Keep alive has timed out. Fault will clear when communication resumes. |
|  | Blinking Orange | Anytime | Battery Voltage is lower than 7V. Either the 12V battery needs to be charged, or the Expansion Hub is running on USB power only. This fault will clear when battery voltage is raised above 7V. This will not be overwritten by the keepalive timeout pattern. |

3 INTEGRATED SENSORS

The REV Robotics Expansion Hub integrates a number of feedback sensors on board. Some of these are user accessible in the latest FTC Android Studio SDK (version 3.1 released May 2017) but others are not yet directly user accessible. These sensors are in some cases also used the Expansion Hub for internal safety monitoring.

- Battery Voltage Monitoring [**Accessible in Ver 3.1**]
- Integrated 9-axis IMU [**Accessible in Ver 3.1**]
 - Bosch BNO055 9-axis absolute orientation sensor
 - Internally connected to I2C port 0 and configured to address 0x28
- Current Monitoring [Not Available in Ver 3.1]
 - Battery
 - I2C Bus
 - Servo Bus
 - Digital Bus
- Per Motor Channel Current Monitoring and Control [Not Available in Ver 3.1]

4 LEGACY SENSOR SUPPORT

4.1 Level Shifter

The Expansion Hub is a 3.3V logic level device, but many of the sensor that teams have previously purchased through companies such as Modern Robotics are 5V logic level devices. Many of these previously purchased sensors can be used with the new system by using a level shifter device. REV Robotics offers a Level Shifter (REV-31-1389) and an optional Sensor Adapter Cable (REV-31-1384) so teams can more easily use their legacy sensors with the new Expansion Hub system.

The REV Robotics Level Shifter is a PCB which generates a 5V output from the 3.3V input and uses a MOSFET on each signal line to create a bidirectional communication appropriate for a variety of digital signals include I2C communication (Figure 5). For more information on how bidirectional level shifting communication is accomplished, please reference the [NXP Application Note AN10441](#).



Figure 5: 3.3V to 5V Level Shifter Board

4.2 Connecting a 5V Motor Encoder

The Level Shifter pin out directly matches the encoder cable pinout for the FTC legal motors. Encoder cables should be plugged directly into the Level Shifter board and then the 4-pin JST PH Cable (REV-31-1407) which is included with the Level Shifter can be plugged into the appropriate Expansion Hub Encoder Port and motors which are terminated with Anderson Power Pole style connectors can use the JST VH to Anderson Power Pole Style (REV-31-1382) cable to connect to the motor output port on the Expansion Hub (Figure 6).

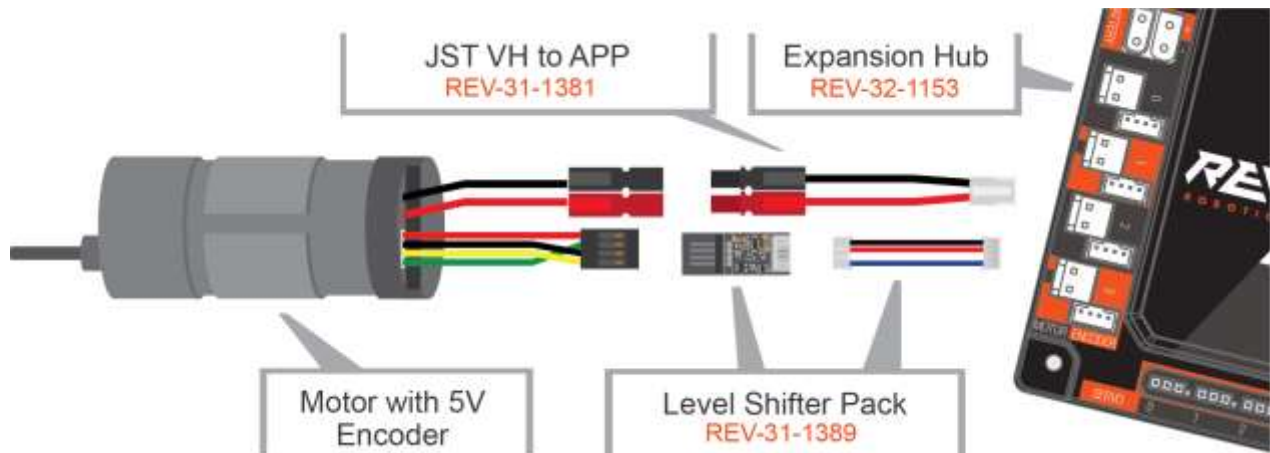

Figure 6: Connecting a Motor with 5V Encoder to an Expansion Hub

All currently sold REV Robotics Motors have been updated to work directly with the Expansion Hub. HD Hex Motors sold before September 2017 with the modern robotics compatible encoder cable and built in power wires have 5V encoders.

4.3 Connecting a 5V Sensor

The I2C sensors from Modern Robotics can be used with the Level Shifter board with a pinout change. Teams can either purchase a Sensor Cable as an add-on to the Level Shifter Kit (REV-31-1389) which will cross over the correct wires, or they can carefully rearrange the pin order on the sensor cable. If using the Sensor add-on cable, connect the sensor to the Expansion Hub as shown in Figure 7. It is recommended to zip tie the connection between the sensor and the sensor cable to prevent accidental disconnects.

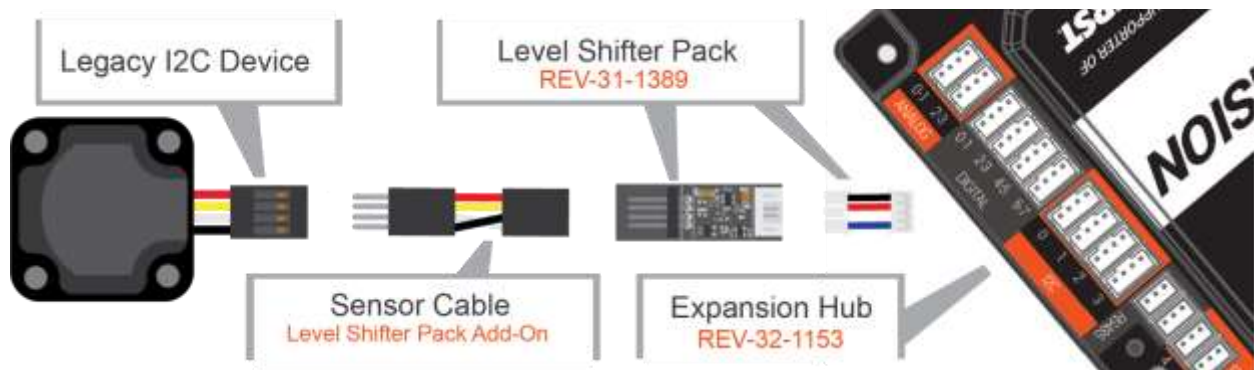
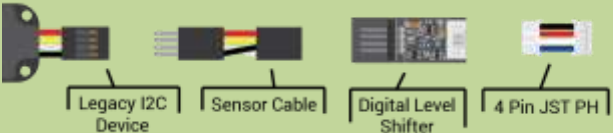
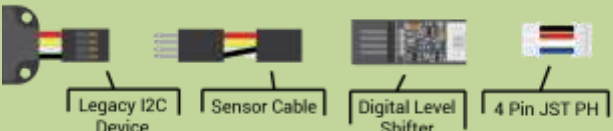
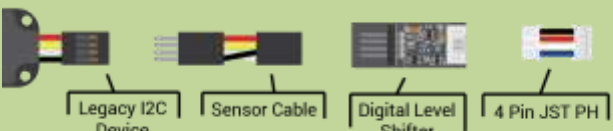
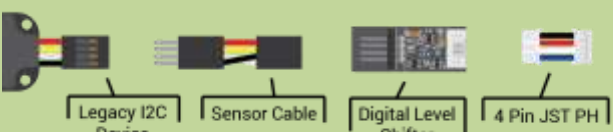
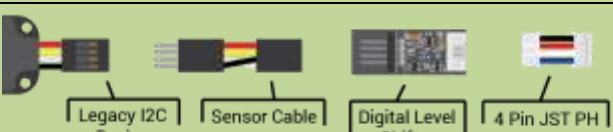
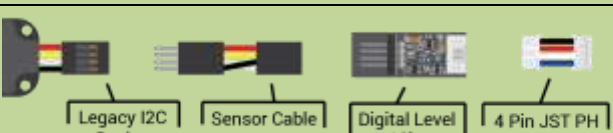
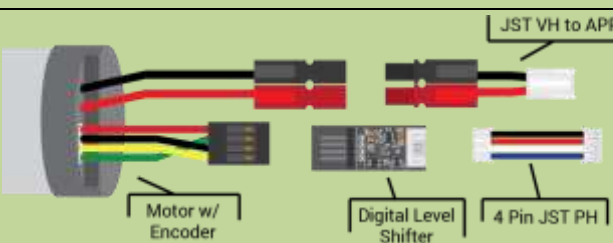

Figure 7: Connecting a Legacy 5V Sensor to an Expansion Hub

4.4 Sensor Compatibility Chart

To determine if your existing sensors can be used with the Expansion Hub and what additional hardware if any is required, reference Table 9.

Table 9: Sensor Compatibility Table

| Sensor | Type | Compatible | Adapters Needed |
|--|--------------|------------|--|
| Absolute Orientation IMU Fusion Breakout - BNO055 2472 Adafruit | I2C | Yes | 3.3V Compatible Custom Wiring Harness Needed |
| RGB Color Sensor with IR filter and White LED - TCS34725 1334 AdaFruit | I2C | Yes | 3.3V Compatible Custom Wiring Harness Needed |
| Color Sensor 45-2018 Modern Robotics | I2C | Yes |  |
| Compass 45-2003 Modern Robotics | I2C | Yes |  |
| Integrating Gyro 45-2005 Modern Robotics | I2C | Yes |  |
| IR Locator 360 45-2009 Modern Robotics | I2C | Yes |  |
| IR Seeker V3 45-2017 Modern Robotics | I2C | Yes |  |
| Ranger Sensor 45-2008 Modern Robotics | I2C | Yes |  |
| NeveRest Motor AM-3461, AM-3102, AM-2964a, AM-3103, AM-3104 AndyMark | Quad Encoder | Yes |  |

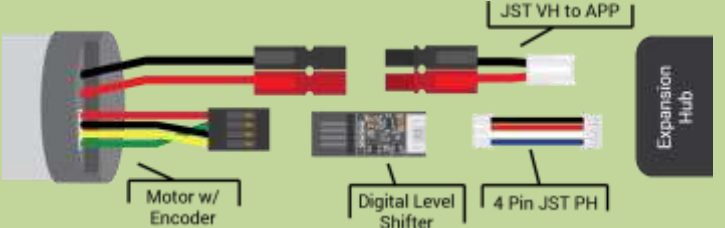
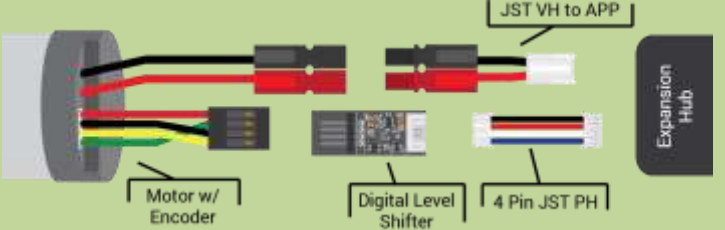
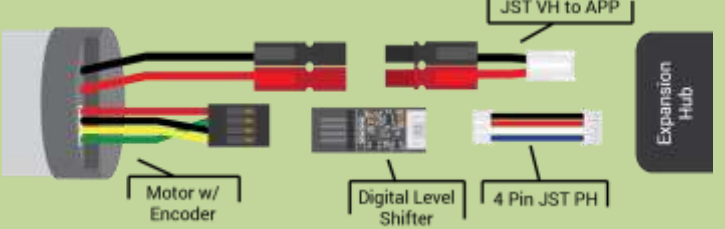
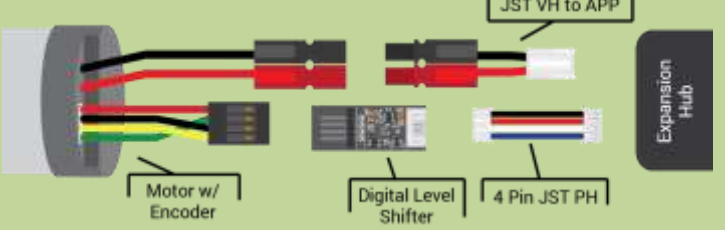
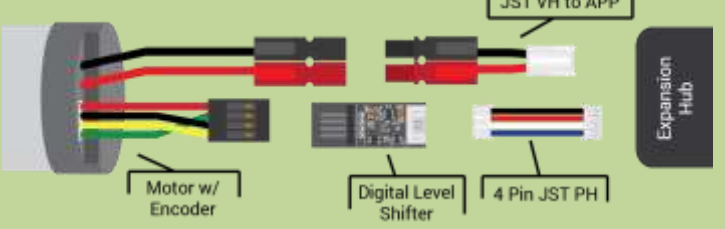
| | | | |
|--|---------------------|------------|--|
| <p>HD Hex Motor V1 (Sold before Sept 2017) REV-41-1301 REV Robotics</p> | <p>Quad Encoder</p> | <p>Yes</p> |  |
| <p>HD Hex Motor V2 REV-41-1301 REV Robotics</p> | <p>Quad Encoder</p> | <p>Yes</p> | <p>Directly Compatible No Custom Adapters Needed</p> |
| <p>Core Hex Motor REV-41-1301 REV Robotics</p> | <p>Quad Encoder</p> | <p>Yes</p> | <p>Directly Compatible No Custom Adapters Needed</p> |
| <p>12v 4mm Motor Kit 50-0119 MATRIX</p> | <p>Quad Encoder</p> | <p>Yes</p> |  |
| <p>12v 6mm Motor Kit 50-0120 MATRIX</p> | <p>Quad Encoder</p> | <p>Yes</p> |  |
| <p>Standard Motor Kit 50-0001 MATRIX</p> | <p>Quad Encoder</p> | <p>Yes</p> |  |
| <p>Max Motor Shaft Encoder Kit W38000 Tetrix</p> | <p>Quad Encoder</p> | <p>Yes</p> |  |
| <p>Limit Switch 45-2401 Modern Robotics</p> | <p>Digital</p> | <p>Yes</p> | <p>No Adapter Needed Custom Wiring Harness Needed</p> |

| | | | |
|--|--------|-----|---|
| Rate Gyro 45-2004 Modern Robotics | Analog | No | Not Officially Supported |
| Optical Distance Sensor 45-2006 Modern Robotics | Analog | No | Not Officially Supported |
| Touch Sensor 45-2007 Modern Robotics | Analog | Yes | No Adapter Needed Custom Wiring Harness Needed |
| Light Sensor 45-2015 Modern Robotics | Analog | No | Not Officially Supported |
| Magnetic Sensor 45-2020 Modern Robotics | Analog | No | Not Officially Supported |

5 Dimensions

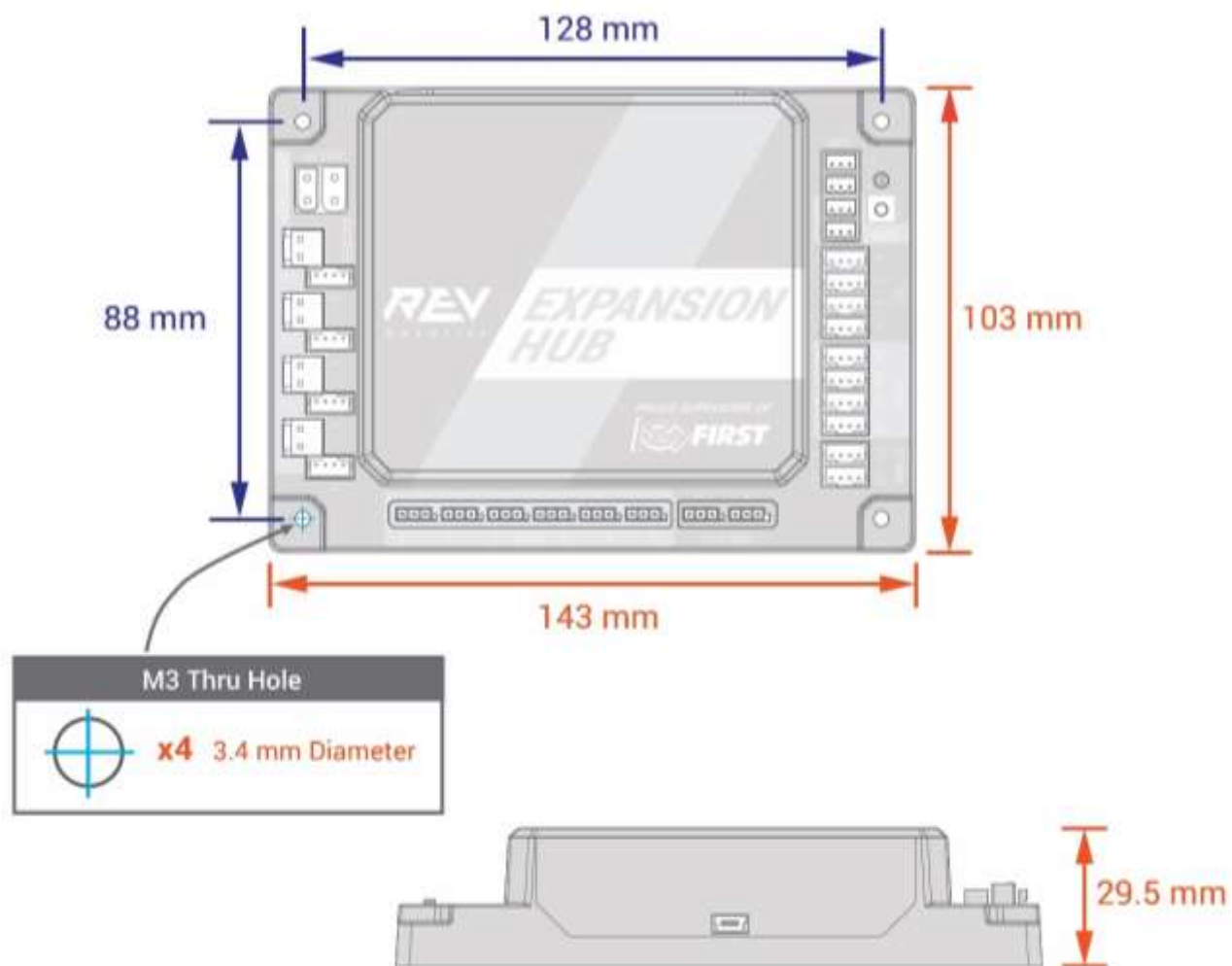

BELOW: IMU Details Shown in Enlarged View

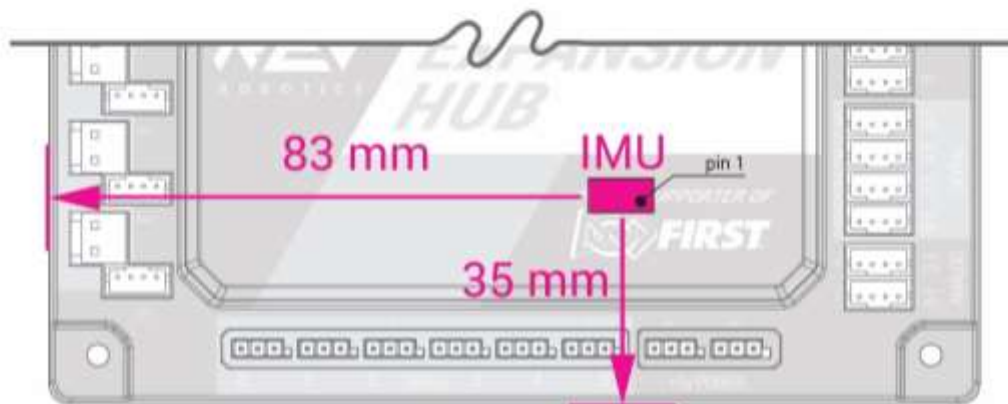

Revisions

| | | |
|-------|------------|---|
| Rev 0 | 6/1/2017 | Initial Release |
| Rev 1 | 6/22/2017 | <ul style="list-style-type: none"> • Overall Improved Wording for Clarity • Corrected the motor connector polarity in the Section 1.2 diagram • Corrected JST to APP (REV-31-1381) Cable Length • Added 4-pin JST PH Extension Board Part Number • Corrected Wire Gauge for JST PH Contacts • Updated miniBot image in Figure 4 • Updated sensor cable drawing to fix wire color error. • Added an improved version of Figure 6. • Added Adafruit Color Sensor to sensor compatibility table |
| Rev 2 | 8/29/2017 | <ul style="list-style-type: none"> • Updated the FTC Control System Guide link to the current wiki • Fixed spelling error • Added instructions for Hub Address Change • Noted that custom wiring harness is needed for all compatible sensors which do not require a level shifter • Corrected Hub Dimensions • Fixed broken reference |
| Rev 3 | 9/29/2017 | <ul style="list-style-type: none"> • Revision to fix revision number on all document sections (meta) • Added LED Status Colors • Added compatibility details on REV motors • Added IMU Location and orientation to the dimension drawing |
| Rev 4 | 11/13/2017 | <ul style="list-style-type: none"> • Added LED color code table for firmware 1_07_00 |