



RIOdduino

USER'S MANUAL

TABLE OF CONTENTS

1	RIODuino OVERVIEW	3
1.1	FEATURES	4
1.2	KIT CONTENTS	4
2	FEATURE DESCRIPTION	5
2.1	ARDUINO COMPATIBILITY	5
2.2	POWER OPTIONS	5
2.2.1	V_{IN} SOURCE REQUIREMENTS	5
2.2.2	POWER SOURCE SELECTION.....	5
2.2.3	POWER SUPPLY CAPABILITIES.....	6
2.3	MXP SIGNALS.....	6
2.3.1	SHARED I ² C.....	7
2.3.2	SHARED UART.....	7
2.4	WS281x RGB LED STRIP CONNECTIONS.....	7
2.5	MOUNTING HOLES.....	8
APPENDIX A	SCHEMATIC.....	9
APPENDIX B	DRAWING.....	10
APPENDIX C	BILL OF MATERIALS.....	11

LIST OF FIGURES

Figure 1-1	RIODuino	3
Figure 2-1	MXP Signal Access.....	6
Figure 2-2	Connecting WS281x LED Strip to RIODuino.....	8

LIST OF TABLES

Table 2-1	V_{IN} Voltage Requirements.....	5
Table 2-2	Automatic Power Selection Truth Table.....	5
Table 2-3	Maximum Supply Current	6
Table 2-4	Shared I ² C Signals	7
Table 2-5	Shared UART Signals	7
Table 2-6	Recommended Mounting Screw Sizes.....	8

1 RIODuino OVERVIEW

The REV Robotics RIODuino is an Arduino Uno R3 compatible microcontroller board designed to plug into the roboRIO MXP (myRIO Expansion Port). Because the RIODuino is a complete microcontroller board, the vast ecosystem of Arduino shields and example code are immediately compatible without having to port any code to the roboRIO. Communicating with the RIODuino is made easy by using the UART or I2C interfaces connected through the MXP to the roboRIO.

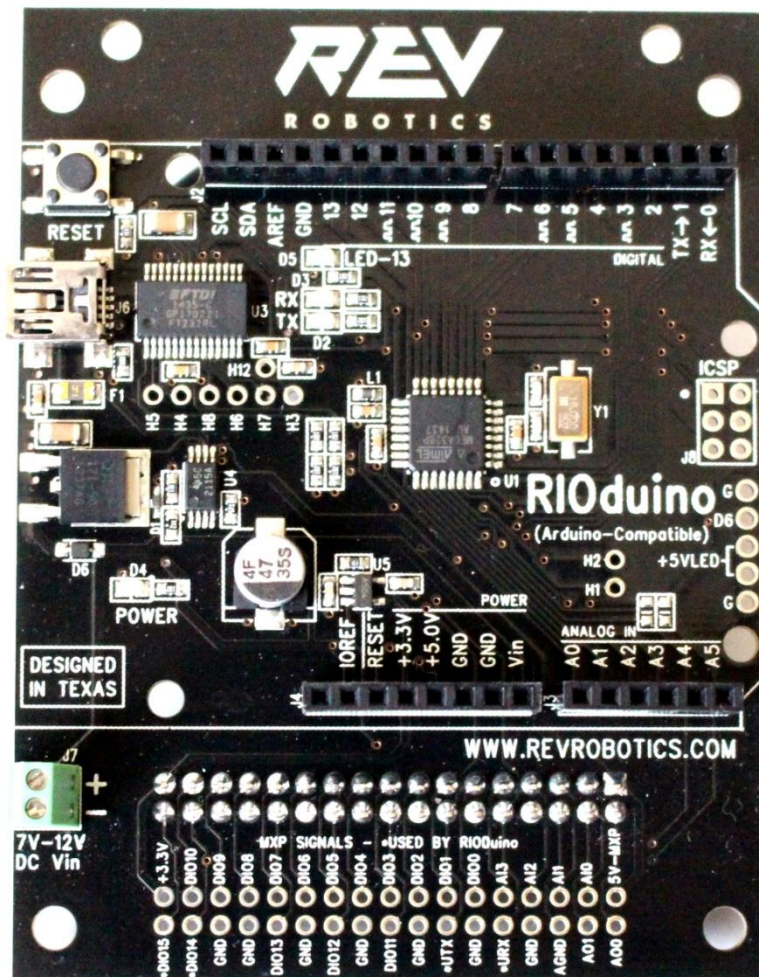

Figure 1-1 RIODuino

1.1 FEATURES

The REV Robotics RIOduino includes the following features:

- Arduino Uno R3 compatible microcontroller board
 - Compatible with virtually all Arduino Uno R3 footprint shields
- 3 auto-selecting power options
 - V_{IN} terminal - 12.0 V (from PDP, VRM, etc.)
 - MXP connector - 5.0 V
 - USB connector - 5.0 V
- Serial connections between RIOduino and roboRIO
 - UART (TTL levels)
 - I²C
- All MXP signals are passed through to 0.1" header positions
 - 4 MXP signals are connected to the RIOduino
 - UART.RX
 - UART.TX
 - DIO14/I2CSCL
 - DIO15/I2CSDA
 - Remaining signals are pass-through only
 - Allows for stacking of MXP boards with provided connector
- Connections for WS281x LED strips
 - Power externally provided
- Mounting holes
 - 2 holes for roboRIO mounting, 4-40 x 3/16" screws
 - 4 Arduino footprint mounting holes, #4 sized screws
 - 4 holes for additional mounting options, #6 sized screws

1.2 KIT CONTENTS

The REV Robotics RIOduino comes with the following:

- RIOduino
- USB A to mini B cable
- Female MXP connector
- 2 roboRIO mounting screws, 4-40 x 3/16"

2 FEATURE DESCRIPTION

The REV Robotics RIOduino is designed to seamlessly integrate the vast Arduino ecosystem into the *FIRST* Robotics Competition control system. This section describes these RIOduino features in detail.

2.1 ARDUINO COMPATIBILITY

The RIOduino is compatible with the latest Arduino UNO R3 footprint. It features an Atmel ATmega328 8-bit microcontroller and can be programmed over USB using the Arduino integrated development environment (IDE). Each board comes with the Arduino bootloader preprogrammed on the ATmega328. Please see the RIOduino Getting Started Guide at www.revrobotics.com/product/riodduino for instructions on how to program the RIOduino for the first time.

For more information on the Arduino UNO R3, the Arduino IDE, compatible shields, and access to the vast Arduino community, please visit arduino.cc.

2.2 POWER OPTIONS

The RIOduino can be powered from one of three power sources: the V_{IN} terminal, MXP connector, or USB connector. It can also supply power to connected circuitry and shields.

2.2.1 V_{IN} SOURCE REQUIREMENTS

When powering the RIOduino from either the V_{IN} pin (J4.8) or the V_{IN} screw terminal (J7) please ensure the voltage meets the input requirements outlined in Table 2-1.

Table 2-1 V_{IN} Voltage Requirements

	MIN	TYP	MAX
V_{IN}	7.0 V	-	12.0 V

If V_{IN} drops below 7.0 V the on-board regulator is at risk of browning out and resetting the RIOduino. If V_{IN} is higher than 12.0 V, the on-board regulator can overheat and be damaged.

2.2.2 POWER SOURCE SELECTION

Circuitry on the RIOduino automatically selects the best source for power with the priority given first to the V_{IN} terminal, then the MXP connector, and then the USB connector. Table 2-2 shows the truth table behind the power source selection.

Table 2-2 Automatic Power Selection Truth Table

$V_{IN} > 2.7 V^1$	$V_{MXP} > V_{USB}$	Selected Source
No	No	USB
	Yes	MXP
Yes	X	V_{IN}

1. Note that V_{IN} must be 7.0 V - 12.0 V for the RIOduino to operate properly, however a V_{IN} greater than 2.7 V will force the selection of V_{IN} as the input source. Please see 2.2.1 V_{IN} SOURCE REQUIREMENTS for more information.

The power selection scheme makes it possible to program and debug over USB without removing the RIoduino from the system.

2.2.3 POWER SUPPLY CAPABILITIES

The RIoduino can supply both 5.0V and 3.3V to connected circuitry and shields. Table 2-3 lists the maximum current capabilities for each supply depending on the RIoduino power source.

Table 2-3 Maximum Supply Current

	Power Source		
	USB	MXP	V _{IN}
3.3 V Rail - I_{MAX}	50 mA	1.5 A ²	50 mA
5.0 V Rail - I_{MAX}¹	500 mA	1.0 A	1.0 A

1. These are the absolute maximums for the 5.0 V rail current. The actual available current will be less and will depend on the 3.3 V rail current and any on-board current draw (including the microcontroller).
2. This is the maximum output current for the roboRIO 3.3 V rail. The actual available current depends on any other devices connected to the roboRIO 3.3V rail.

When powered by the MXP connector, the on-board 3.3 V regulator (U5) is put into a shutdown mode and 3.3 V power is provided by the roboRIO. Pin 8 on the MXP connector (J1) is connected to the SHUTDOWN pin (U5.3) and is tied to ground once it is connected to the matching pin 8 on the roboRIO MXP.

2.3 MXP SIGNALS

All MXP signals are routed to 2x17 0.1" spaced grid of holes along the bottom edge of the board, see Figure 2-1.

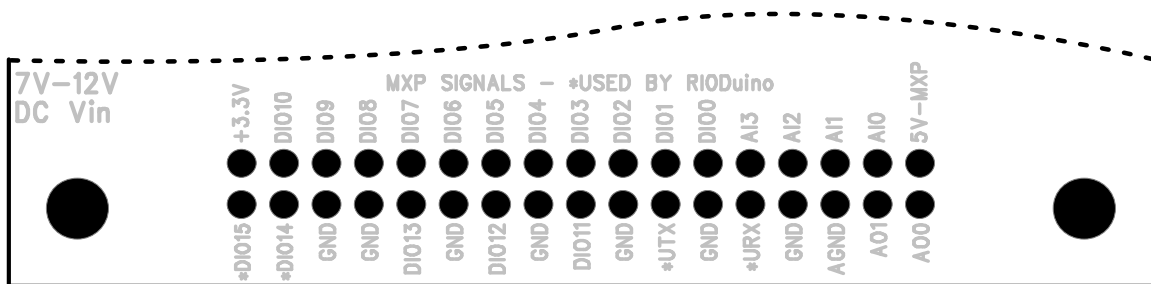

Figure 2-1 MXP Signal Access

The included female MXP connector can be soldered to these holes and used in tandem with the REV Robotics MXP Extension Cable (REV-1-1118) to stack an additional MXP board like the REV More Board (REV-11-1100).

Both I²C and UART are connected between the roboRIO and the RIoduino providing the means to communicate between the two.

2.3.1 SHARED I²C

Table 2-4 shows which signals are shared for I²C.

Table 2-4 Shared I²C Signals

RIOduino Signal	RIOduino Shield Pin	MXP Pin	MXP Signal
AD4/SDA	J3.5	J1.34	DIO15/I2CSDA
AD5/SCL	J3.6	J1.32	DIO14/I2CSCL

As with any I²C bus, pull-up resistors are required for both SCL and SDA. To keep AD4 and AD5 free for analog use, the RIOduino has two unpopulated positions (R12, R13) for 2.2 k Ω 0603 surface mount resistors. When used with the roboRIO, these external resistors are not needed because the roboRIO has internal pull-up resistors. For other applications, these resistors can be added. Please see APPENDIX A SCHEMATIC and APPENDIX B DRAWING for the schematic and component placement drawing.

2.3.2 SHARED UART

Table 2-5 shows which signals are shared for UART.

Table 2-5 Shared UART Signals

RIOduino Signal	RIOduino Shield Pin	MXP Pin	MXP Signal
IO0/RX	J5.1	J1.14	UART.TX
IO1/TX	J5.2	J1.10	UART.RX

CAUTION

The UART signals are at TTL levels. Do not connect directly to a RS-232 serial port without an RS-232 to TTL converter.

The UART on the ATmega328 is connected to both the MXP connector and the on-board USB to Serial converter through 1 k Ω resistors. These resistors prevent either the roboRIO or the USB to Serial converter from forcibly driving the bus when another UART device is connected through the shield headers.

2.4 WS281x RGB LED STRIP CONNECTIONS

A popular application for Arduino-compatible boards like the RIOduino is to control addressable RGB LED strips like the WS2811 and WS2812 based strips. The RIOduino includes five plated-through holes that make it easy to connect one of these strips and its external power source. Figure 2-2 shows how to wire a WS281x LED strip with an external 5V supply.

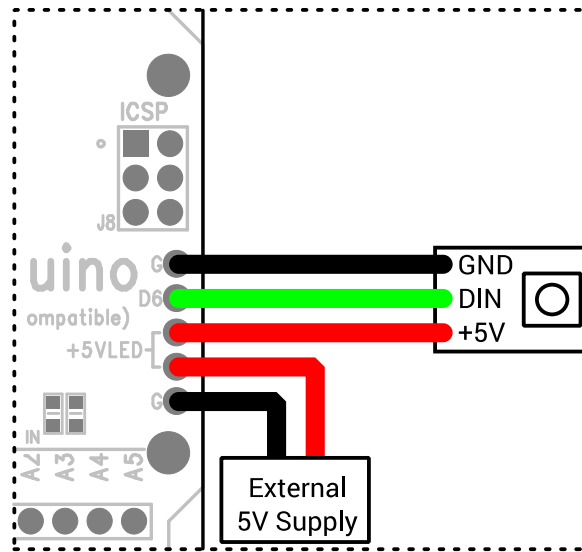

Figure 2-2 Connecting WS281x LED Strip to RIOduino

The data line for the strip is connected to the D6 output of the RIOduino while power is provided externally. LED strips can draw a large amount of current, so care should be given to ensure the external power source can provide enough current.

2.5 MOUNTING HOLES

The RIOduino has 10 total mounting hole locations throughout the board. Please see APPENDIX B DRAWING for the mounting hole placement. Table 2-6 lists the recommended mounting screw sizes.

Table 2-6 Recommended Mounting Screw Sizes

Mounting Hole	Quantity	Recommended Screw Size
roboRIO	2	4-40 x 3/16" machine screw
Arduino footprint	4	#4 machine screw
General mounting	4	#6 machine screw

The general mounting holes give flexibility in mounting the board, either mounted directly on the roboRIO or externally using the REV Robotics MXP Extension Cable (REV-1-1118).

APPENDIX A SCHEMATIC

Appendix A shows the schematic for the REV Robotics R1Oduino.

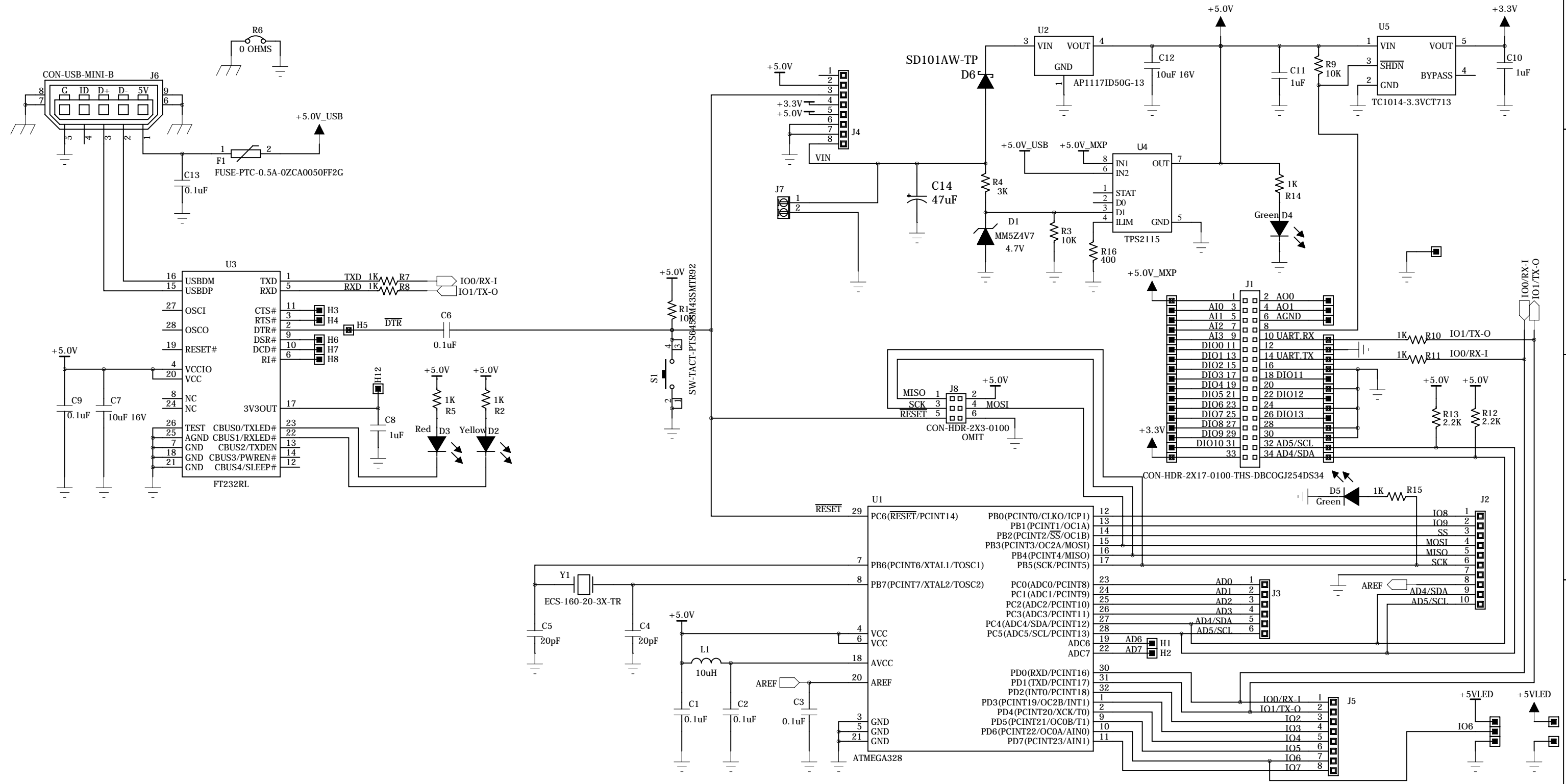

DESIGNER	REVISION	DATE
DAY	A	11/14/2014
PROJECT		
RIODuino		
DESCRIPTION		
Arduino Compatible MXP Microcontroller Board		
FILENAME		
RIODuino-RevA.sch		



REV
ROBOTICS

WWW.REVROBOTICS.COM

PART NO.	RR-RIODUINO-BD-A	SHEET	1 OF 1
----------	------------------	-------	--------

APPENDIX B DRAWING

Appendix B shows the component placement and dimensional drawing of the REV Robotics R10duino.

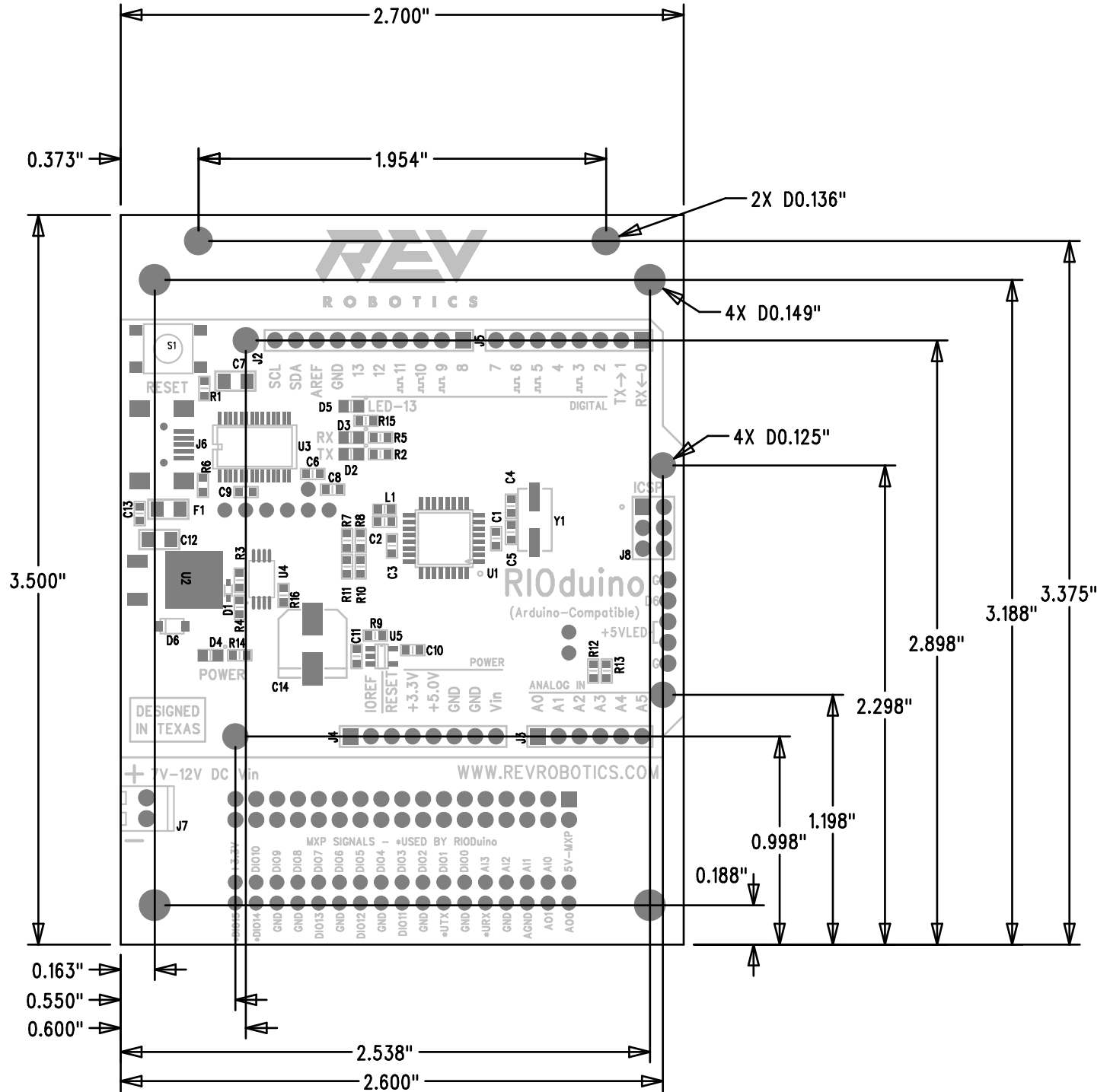

APPENDIX C BILL OF MATERIALS

Appendix C shows the bill of materials for the REV Robotics RIoduino.

RIoduino Bill of Materials					
Item	Ref	Qty	Description	Mfg	Part Number
1	C1-3 C6 C9 C13	6	CAP CER 0.1UF 50V Y5V 0603	Samsung	CL10F104ZB8NNNC
2	C14	1	CAP ALUM 47UF 25V 20% SMD	Nichicon	UWT1E470MCL6GS
3	C4-5	2	CAP CER 20PF 50V 5% NP0 0603	Samsung	CL10C200JB8NCNC
4	C7 C12	2	CAP CER 10UF 16V Y5V 1206	Samsung	CL31F106ZOHNNNE
5	C8 C10-11	3	CAP CER 1UF 25V 10% X5R 0603	Murata	GRM188R61E105KA12D
6	D1	1	DIODE ZENER 4.7V 200MW SOD523F	Fairchild	MM5Z4V7
7	D2	1	LED CHIPLD 588NM YLW 0805 SMD	OSRAM	LY R976-PS-36
8	D3	1	LED CHIPLD 645NM RED DIFF 0805	OSRAM	LH R974-LP-1
9	D4-5	2	LED CHIPLD 570NM GREEN 0805 SMD	OSRAM	LG R971-KN-1
10	D6	1	DIODE SCHOTTKY 40V SOD323	MCC	SD101CWS-TP
11	F1	1	PTC RESTTBLE 0.50A 8V CHIP 1206	Bel	OZCA0050FF2G
12	J1	1	2x17-Pin Female Box Header, 0.1", Keyed	Xiamen	DBC0GJ254DS34
13	J2	1	CONN FEMALE 10POS .1" SMD TIN	Sullins	PPTC101LFBN-RC
14	J3	1	CONN FEMALE 6POS .1" SMD TIN	Sullins	PPTC061LFBN-RC
15	J4-5	2	CONN FEMALE 8POS .1" SMD TIN	Sullins	PPTC081LFBN-RC
16	J6	1	CONN MINI USB RCPT RA TYPE B SMD	EDAC	690-005-299-043
17	J7	1	CONN TERM BLOCK 2.54MM 2POS PCB	On Shore	OSTVN02A150
18	L1	1	INDUCTOR MULTILAYER 10000NH 0603	Abracon	AIML-0603-100K-T
19	R1 R3 R9	3	RES 10K OHM 1/10W 5% 0603 SMD	Rohm	MCR03ERTJ103
21	R16	1	RES 470 OHM 1/10W 5% 0603 SMD	Rohm	MCR03ERTJ471
22	R2 R5 R7-8 R10-11 R14-15	8	RES 1.0K OHM 1/10W 5% 0603 SMD	Yageo	RC0603JR-071KL
23	R4	1	RES 3K OHM 1/10W 5% 0603 SMD	Rohm	MCR03ERTJ302
24	R6	1	RES 0.0 OHM 1/10W JUMP 0603	Samsung	RC1608J000CS
25	SW1	1	SWITCH TACTILE SPST-NO 0.05A 12V	C&K	PTS645SM43SMTR92 LFS
26	U1	1	IC MCU 8BIT 32KB FLASH 32TQFP	Atmel	ATMEGA328-AU
27	U2	1	IC REG LDO 5V 1A TO252-3	Diodes Inc.	AP1117ID50G-13
28	U3	1	IC USB FS SERIAL UART 28-SSOP	FTDI	FT232RL-REEL
29	U4	1	C OR CTRLR SRC SELECT 8TSSOP	Texas Instruments	TPS2115APWR
30	U5	1	IC REG LDO 3.3V 50MA SOT23-5	Microchip	TC1014-3.3VCT713
31	Y1	1	CRYSTAL 16MHZ 20PF SMD	ECS	ECS-160-20-3X-TR
32	PCB1	1	RIoduino Rev. A PCB, 2-layer, 1 oz	REV Robotics	RR-RIODUINO-BD-A
Do not populate list					
20	R12-13	2	RES 2.2K OHM 1/10W 5% 0603 SMD	Rohm	MCR03ERTJ222