



# MORE BOARD

**USER'S MANUAL**

# TABLE OF CONTENTS

1	MORE BOARD OVERVIEW.....	3
1.1	FEATURES .....	4
1.2	KIT CONTENTS .....	4
2	FEATURE DESCRIPTION .....	5
2.1	SCREW TERMINALS.....	5
2.1.1	USING THE SCREW TERMINALS .....	5
2.2	HEADERS .....	6
2.2.1	PWM CONNECTIONS .....	6
2.2.2	MXP PASS-THROUGH CONNECTOR .....	6
2.3	POWER RAILS.....	6
2.3.1	JUMPER SHUNTS .....	6
2.3.2	SOLDER JUMPERS .....	7
2.3.3	ANALOG SIGNALS.....	7
2.4	PROTOTYPING AREA.....	8
2.5	MOUNTING HOLES.....	8
APPENDIX A	SCHEMATIC.....	9
APPENDIX B	DIMENSIONS.....	11
APPENDIX C	BOARD REVISIONS .....	12

## LIST OF FIGURES

Figure 1-1	More Board .....	3
Figure 2-1	Header Pinouts.....	6
Figure 2-2	Solder Jumpers .....	7
Figure 2-3	Prototype Area Hole Pattern .....	8

## LIST OF TABLES

Table 2-1	Screw Terminal Arrangement.....	5
Table 2-2	Recommended Wire Size.....	5
Table 2-3	Recommended Mounting Screw Sizes.....	8

# 1 MORE BOARD OVERVIEW

The REV Robotics More Board is a passive expansion board designed for the roboRIO MXP (myRIO Expansion Port). Every MXP signal is broken out to screw terminals and common 3-pin headers, effectively doubling the available Analog and Digital IO/PWM ports on the roboRIO.



Figure 1-1 More Board

## 1.1 FEATURES

The REV Robotics More Board includes the following features:

- Access to all MXP signals
  - 3.5 mm screw terminals
  - 3-pin servo-style 0.1" headers
  - Single in-line 0.1" headers for UART, SPI, and I<sup>2</sup>C
- MXP pass-through connector
  - Use additional MXP boards with an extension cable
- Configurable power rails
  - Pass-through MXP 3.3V or MXP 5.0V
  - External power compatible
    - Avoid brownout issues
  - Movable jumper shunts and solder jumpers
  - Separately select UART, SPI, I<sup>2</sup>C, and DIO V<sub>CC</sub> sources
- Prototyping area
  - Standard breadboard-style layout
  - 0.1" grid holes
- Power rail LED indicators
- Mounting holes
  - 2 holes for roboRIO mounting, 4-40 x 3/16" screws
  - 4 holes for additional mounting options, #6 sized screws

## 1.2 KIT CONTENTS

The REV Robotics More Board comes with the following:

- 1 - More Board
- 2 - 4-40 x 3/16" mounting screws

# 2 FEATURE DESCRIPTION

The REV Robotics More Board includes a range of features designed to make expanding the roboRIO MXP port simple and easy. This section describes each of these features in detail.

## 2.1 SCREW TERMINALS

Each MXP signal pin is broken out to a set of 3.5 mm screw terminals, labeled with their corresponding signal name. The signals are grouped by major pin function in the following order:

**Table 2-1 Screw Terminal Arrangement**

More Board Screw Terminals			
MXP Signal	Left Terminal (J3)	Right Terminal (J2)	MXP Signal
+5.0V	1	16	+5.0V
+3.3V	2	15	+3.3V
DIO0	3	14	DIO11
DIO1	4	13	DIO12
DIO2	5	12	DIO13
DIO3	6	11	DIO14
DIO4	7	10	DIO15
DIO5	8	9	GND
DIO6	9	8	+5.0V
DIO7	10	7	AIN0
DIO8	11	6	AIN1
DIO9	12	5	AIN2
DIO10	13	4	AIN3
GND	14	3	AOUT0
UART.RX	15	2	AOUT1
UART.TX	16	1	AGND

### 2.1.1 USING THE SCREW TERMINALS

Using a small slotted screw driver, loosen the screw at the top of the terminal you wish to use. Insert stripped wire into the opening on the side of the terminal. While holding the wire in place, tighten the screw until the wire is held snug by the terminal. Please see Table 2-2 for the recommended wire size.

**Table 2-2 Recommended Wire Size**

Wire Type	Stranded (Recommended)
	Solid Core
Wire Size (Minimum)	28 AWG
Wire Size (Maximum)	16 AWG
Stripped Length	5.5 mm (0.22")

## 2.2 HEADERS

Each MXP signal pin is broken out to sets of 0.1" pin-headers. Every Digital IO (DIO), Analog Input, and Analog Output is brought out to 3-pin headers with the standard servo-style pinout: [GROUND][POWER][SIGNAL]. Serial interfaces shared with DIO, I<sup>2</sup>C and SPI, are also brought out to single line headers. UART is only brought out in a single line header because it is not shared with any DIO. Each signal is labeled next to its corresponding header group. Figure 2-1 shows these pinouts.

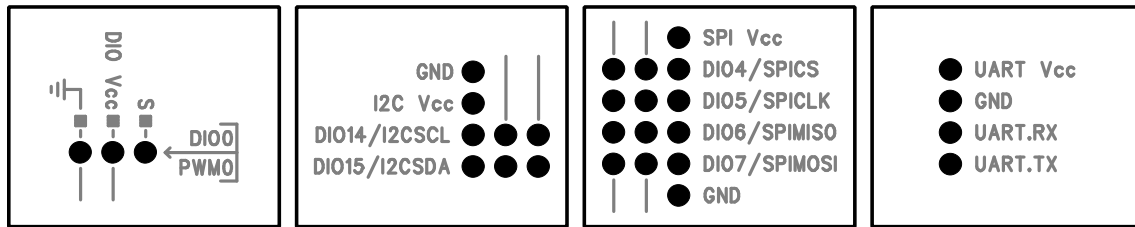

Figure 2-1 Header Pinouts

### 2.2.1 PWM CONNECTIONS

PWM signals are shared with several DIO on the MXP. These signals, like all MXP signals, are passed through and broken out without any intermediate active circuitry. For example, these PWM connections can be used to safely connect motor controllers, keeping their PWM signals under control of the roboRIO.

#### CAUTION

Do not connect Servo Motors to the More Board.

The MXP and the More Board are not designed to provide power to Servo Motors. Even though 5.0V or 3.3V is provided on the middle pin of the 3-pin headers, the required 6.0V is not brought out through the MXP and therefore not available on the More Board. Servos must be connected to the roboRIO PWM ports.

### 2.2.2 MXP PASS-THROUGH CONNECTOR

All MXP signals are routed to a female MXP header (J4) at the bottom edge of the More Board. Every signal is passed through this connector so that additional MXP accessories can be connected with the REV Robotics MXP Extension Cable (REV-11-1118).

## 2.3 POWER RAILS

The MXP can provide both 5.0V and 3.3V to connected expansion boards. Four separate rails exist on the More Board, each with the ability to use the MXP 5.0V or 3.3V. These four rails are DIO VCC, I<sup>2</sup>C V<sub>CC</sub>, SPI V<sub>CC</sub>, and UART V<sub>CC</sub>. Each rail has two methods of selecting the supplied voltage: a jumper shunt and a solder jumper.

Both the 5.0V and 3.3V rails can be disconnected with jumpers JP16 and JP14, respectively. This makes it possible to connect an external power source to these rails.

### 2.3.1 JUMPER SHUNTS

The 2-pin jumper shunts are installed on 3-pin headers and connect the middle pin to one of the outer pins. Move the jumper to the side labeled with the desired voltage.

### 2.3.2 SOLDER JUMPERS

Next to each 3-pin power rail header is a set of two solder jumpers. These provide a more secure way to select the voltage rail, but require the use of a soldering iron. To select a voltage rail, first remove the jumper shunt. Then, on the solder jumper associated with the desired voltage label, flow a small quantity of solder onto the fork shaped pads so that the connection is made between the prongs. See Figure 2-2 for a before and after example of selecting 5.0V for DIO V<sub>CC</sub> using the solder jumper.

#### CAUTION

Take care not to short both solder jumpers. This can create a short between the 5.0V and 3.3V rails and damage the roboRIO. It is also recommended that you remove the 2-pin jumper shunt when using the solder jumpers to prevent the accidental shorting of the rails. See Figure 2-2 for examples of proper solder jumper usage.

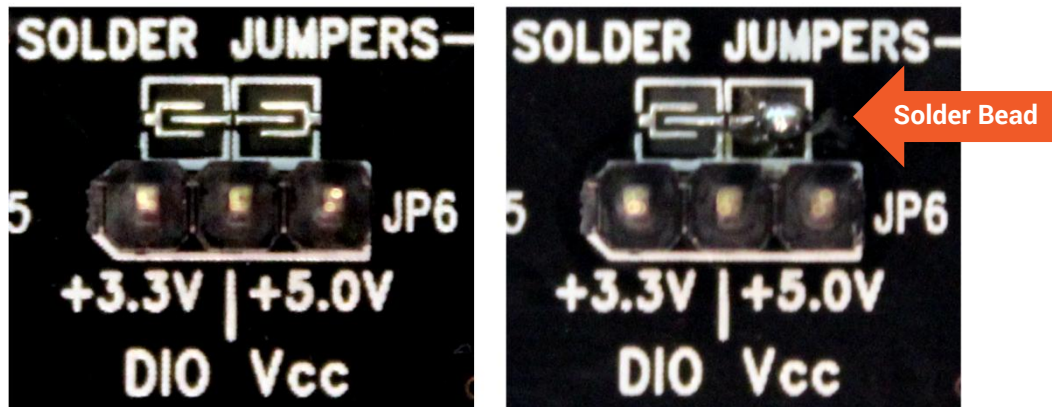

Figure 2-2 Solder Jumpers

### 2.3.3 ANALOG SIGNALS

The 5.0V rail is directly connected to the analog headers because the roboRIO's Analog to Digital Converter (ADC) measures between 0V and 5.0V. Analog ground (AGND) is broken out from the MXP and kept isolated from digital ground (GND).

## 2.4 PROTOTYPING AREA

At the center of the More Board is a 16 x 16 0.1" grid prototyping area. The plated-through holes are arranged like a standard breadboard with bus strips and terminal strips. Six bus strips run vertically with two on the left, two in the center, and two on the right. These bus strips are electrically connected through the entire column (1 - 16). There are 16 5-pin terminal strips on each side of the center bus strips (A-E and F-J). The 5 pins are electrically connected in each terminal strip. Figure 2-3 shows the prototyping area hole pattern.

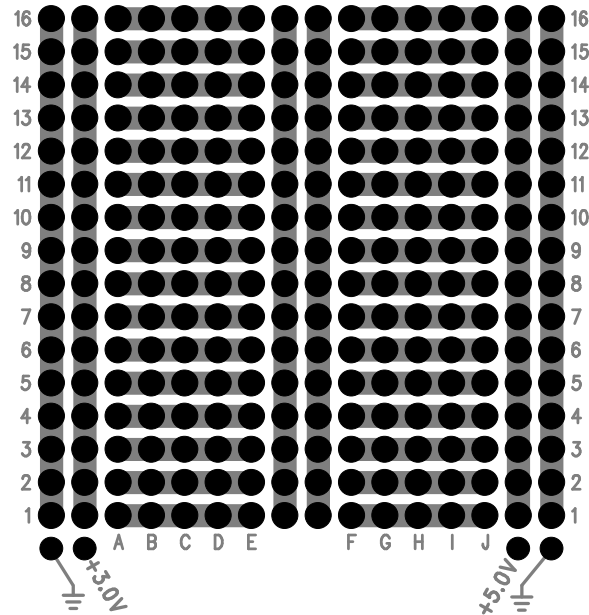

**Figure 2-3 Prototype Area Hole Pattern**

By default, the bus strips are not connected to power or ground. 5.0V, 3.3V, and ground must be connected by soldering a connection between the power pads (located at the bottom of the prototyping area) and the bus strips.

## 2.5 MOUNTING HOLES

The More Board has 6 mounting hole locations throughout the board: 2 roboRIO mounting holes and 4 general mounting holes. These mounting holes give flexibility in mounting the board, either mounted directly on the roboRIO or externally using the REV Robotics MXP Extension Cable (REV-11-1118). Please see APPENDIX B DIMENSIONS for the mounting hole placements. Table 2-3 shows the recommended mounting screw sizes.

**Table 2-3 Recommended Mounting Screw Sizes**

Mounting Hole	Quantity	Recommended Screw Size
roboRIO	2	4-40 x 3/16" Machine Screw
General Mounting	4	#6 Machine Screw



# APPENDIX A SCHEMATIC

Appendix A shows the schematic for the REV Robotics More Board.

### Left Screw Terminals

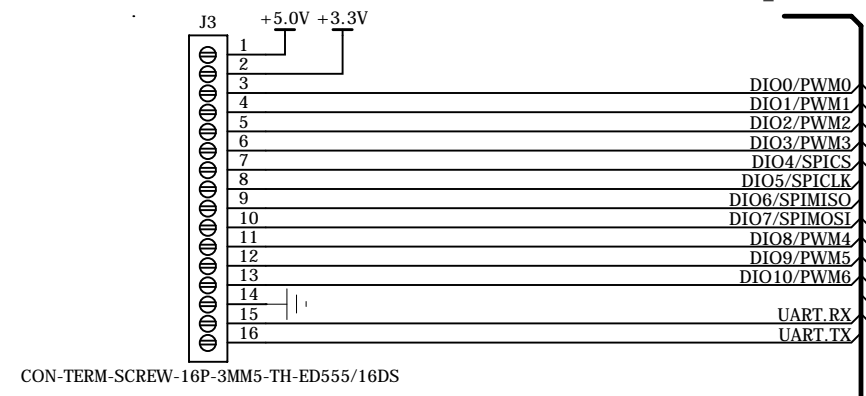

### Right Screw Terminals

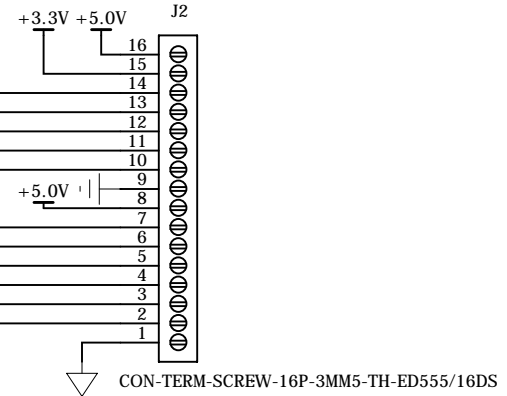

### MXP Connector

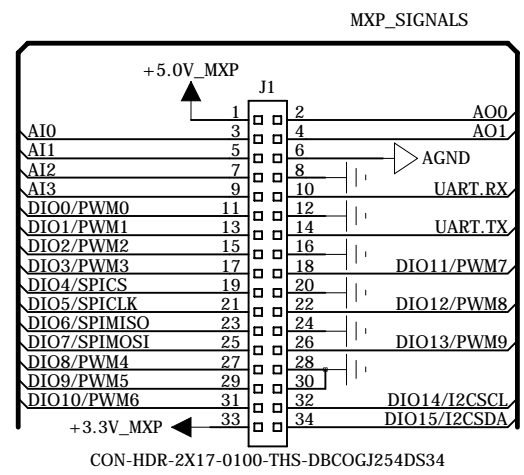

### MXP Socket

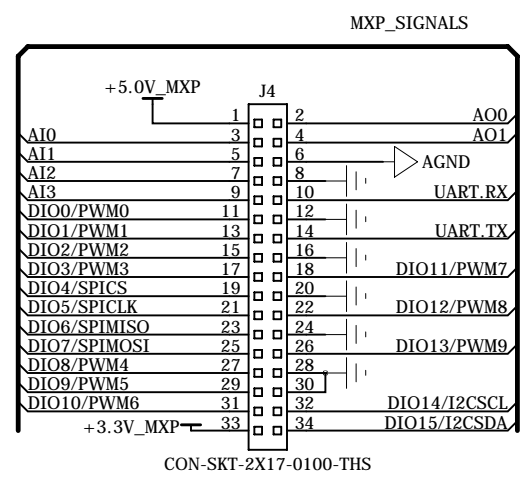

### Prototype Area

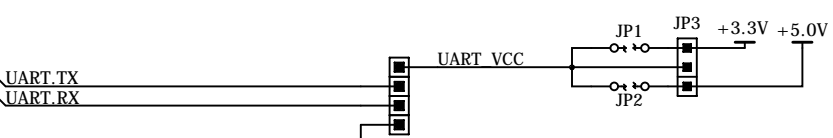
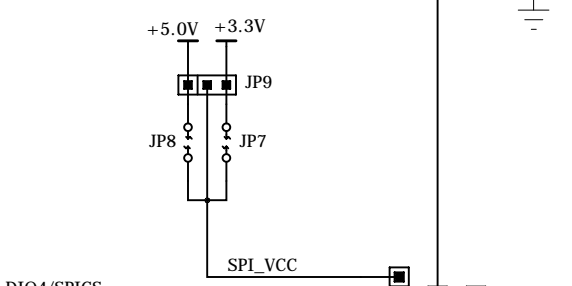
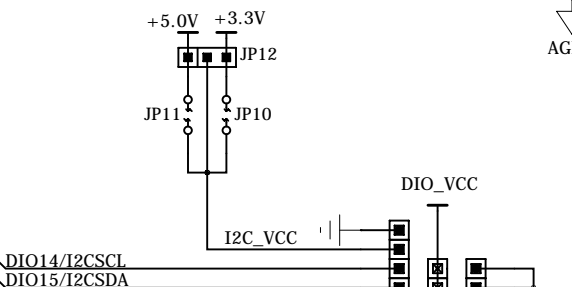
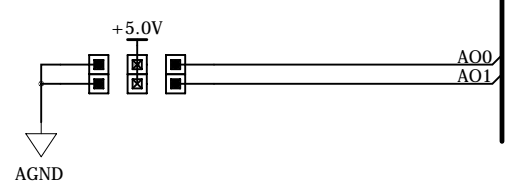
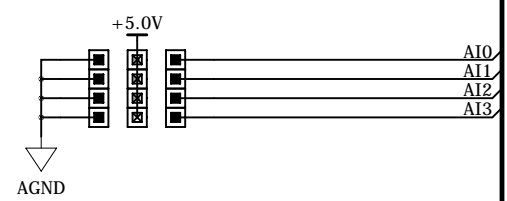
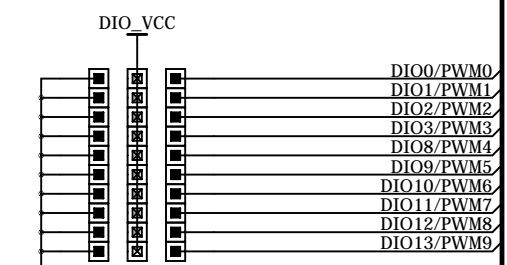
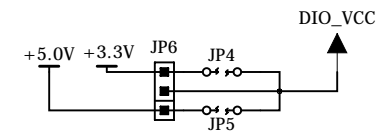
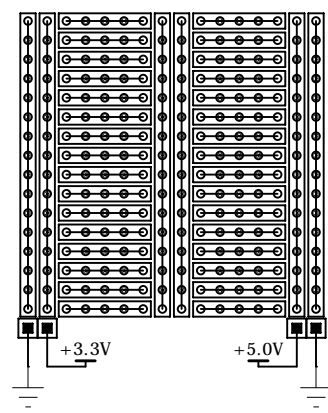

DESIGNER DAY	REVISION B	DATE 6/7/2015
PROJECT More Board		
DESCRIPTION MXP Breakout Board		
FILENAME moreboard-revB.sch		



WWW.REVROBOTICS.COM

PART NO. RR-MORE-BD-B	SHEET 1 OF 1
--------------------------	-----------------

# APPENDIX B DIMENSIONS

Appendix B shows a dimensional drawing of the REV Robotics More Board. All dimensions are in mils.

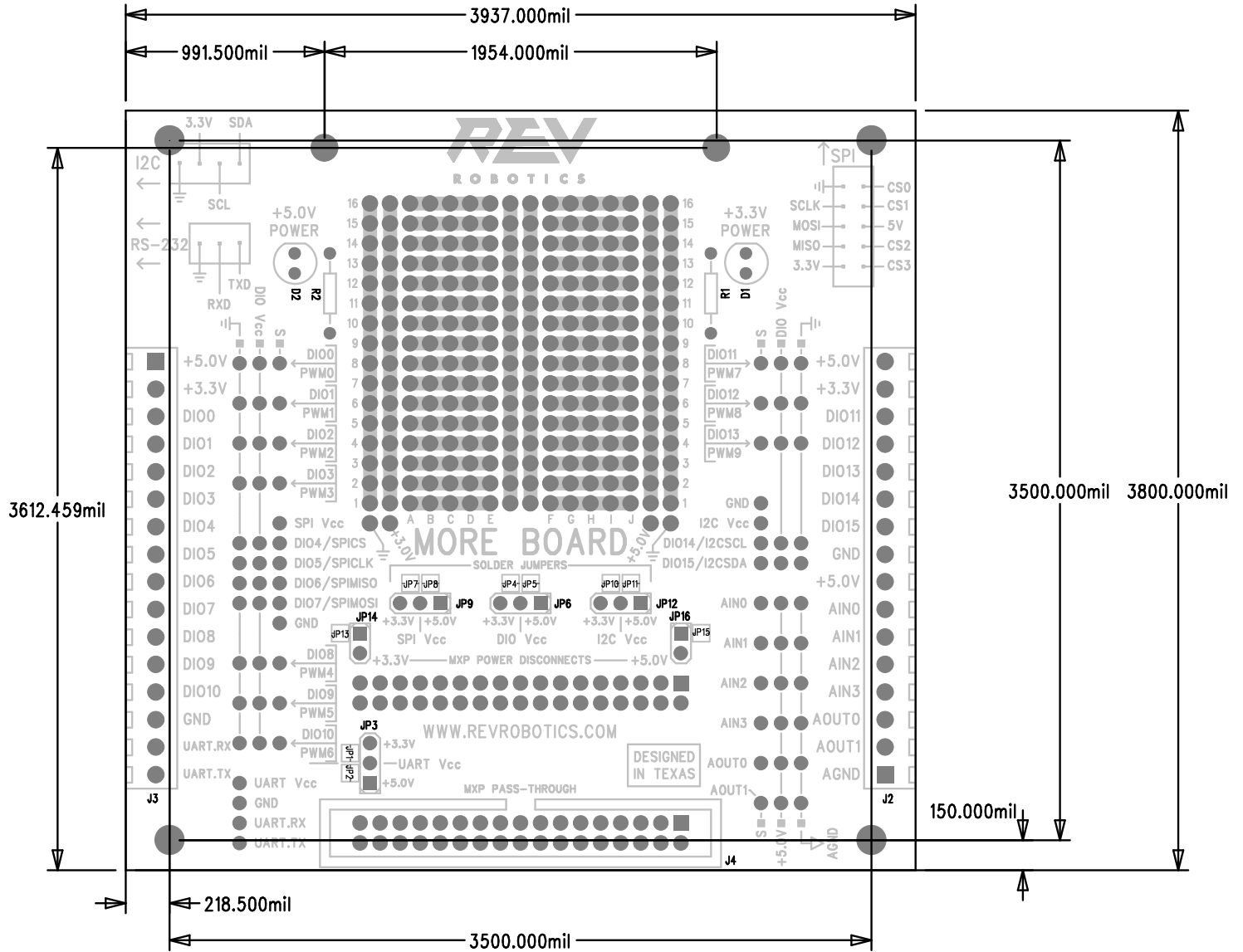

# APPENDIX C BOARD REVISIONS

Version	Description	Date
A1	<ul style="list-style-type: none"><li>• Initial release</li></ul>	11/14/2014
B	<ul style="list-style-type: none"><li>• Added 5V and 3.3V power indicator LEDs.</li><li>• Adjusted 5V rail routing to fully isolate rail when jumper is removed.</li><li>• Added MXP pass-through connector</li><li>• Silk screen improvements</li></ul>	6/7/2015